

# Best Practice



Issue 680 | August 2024 | 0121 824 4744 | [www.bestpracticeuk.co.uk](http://www.bestpracticeuk.co.uk)

Search for us on LinkedIn  and follow us on X  @best\_pra\_uk or download our iOS app



## Christeyns Food Hygiene Wins Gold Medal for Sustainability

Christeyns Food Hygiene has been awarded the prestigious EcoVadis Gold Medal for its commitment to sustainability and responsible business practices.

EcoVadis is the world's largest and most trusted provider of business sustainability ratings, creating a global network of more than 130,000+ rated companies. It evaluates companies' sustainability performance across various criteria. This Gold Medal achievement for Christeyns Food Hygiene underlines the firm's dedication to environmental stewardship, labour practices, ethical conduct, and sustainable procurement.



As part of the evaluation performance, the business is meticulously assessed across these categories, with evaluation of company policies, procedures, and key performance indicators (KPIs).

This places us in the top 5% worldwide of companies recognised with this esteemed award.

Warrington-based CFH manufactures premium hygiene products and along with its partners supplies solutions for the safe cleaning and disinfection of food and beverage plants and food retail businesses across the country. Recognising the critical role that cleaning and disinfection protocols play in upholding food safety management systems, the firm is committed to enhancing clients' operations whilst leading the sector in sustainable business practices.

"At Christeyns Food Hygiene we have long been conscious of the impact that our products and services have on the environment and on our customer's operations," states Chris Bayliss, CFH

UK Sales Director. "This award is recognition and validation of the long-term efforts we have in place to ensure and support food safety and hygiene in our customer's sites in a sustainable way for now and the future."



Christeyns Food Hygiene is part of the international hygiene group, Christeyns, with headquarters in Ghent, Belgium. The group has subscribed to the Responsible Care Global Charter committed to a corporate leadership culture that safeguards people and the environment, strengthens chemicals management systems, influences business partners, promotes safe management of chemicals, engages stakeholders and contributes to sustainability. The company has also signed up to the UN Global Compact initiative.

<https://www.christeyns.com/uk-en>



**Smart Freight**  
see them on page.....5



**SEMOTA**  
Continuous Remote Monitoring

**Interface Force**  
see them on page.....12-13



**BASA**  
see them on page.....18



**Bona**<sup>®</sup>  
see them on page....24-25

## Ionic Systems



Ionic Systems proudly unveiled the groundbreaking Endura™ anti-rotational waterfed pole at the Manchester Cleaning Show 2024, drawing acclaim for its innovative design and enhanced durability. The Endura's exceptional performance promises to revolutionise the cleaning industry by providing superior control and ease of use for professionals.

The show also witnessed the remarkable popularity of our Roof Wand™, a versatile tool designed to tackle even the most challenging roof cleaning tasks with unmatched efficiency. Visitors to our booth were impressed

by its effectiveness and ease of operation, solidifying its status as a must-have for any serious cleaning professional.

We are thrilled with the success of this year's event and are already looking forward to returning next year. Our commitment to innovation and excellence remains unwavering, and we are excited to showcase even more cutting-edge solutions in the future.

In addition to our product offerings, we continue to support the industry through our training academy, the British Window Cleaning Academy (BWCA). Our comprehensive



training programs are tailored for facilities managers and business owners eager to enhance their own and their employees' exterior cleaning skills. Join us to stay ahead in the competitive cleaning industry.

T +44 (0)1793 871386  
[info@ionicsystems.com](mailto:info@ionicsystems.com)  
[www.ionicsystems.com](http://www.ionicsystems.com)

# Contents

BP Recommends	3-6
HSE	7-8
Logistics	9
Lighting	10-11
Testing	12-13
Testing & Measurement	14
Industrial	15
Oil & Gas	16
Health & Safety	17
Industry	18
Industrial Cleaning	19
Industry	20
Engineering	21
Industrial	22
Industrial Hinges	23
Industrial Flooring	24-25
Warehouse & Logistics	26-27
Machine Safety	28-29
Classifieds	30
Handling & Storage	31
Electrical Vehicle	32

## Contact

### Publication Management

**Thomas Reilly**  
Sales Manager  
T 07539 070158  
sales@bestpracticeuk.co.uk

### Production

**Robert Sharp**  
Production Manager  
production@businessandindustrytoday.co.uk

### Accounts

**Paul Whitaker**  
Accounts Manager  
T 0121 824 4742  
accounts@bestpracticeuk.co.uk

### Editorial

**Gina Burton**  
Editor  
gina@freshmedia-uk.co.uk

**Best Practice** 

www.bestpracticeuk.co.uk  
August 2024 | Issue 680

# Editor's Notes

**Liz Dickinson**  
Editor



Welcome to our August Summer edition of Best Practice. With renewed focus on sustainability targets across the industry, we are delighted to hear that Christeys Food Hygiene is now the proud recipient of the prestigious EcoVadis Gold Medal for commitment to sustainability and responsible business practices. [Read more on page 1 about this extraordinary achievement.](#)

Bradshaw Electric Vehicles exclusively supply the Goupils: a range of all-electric light commercial vehicle models. They are equipped with a single-phase onboard charger and handily can be plugged into any standard 230-volt domestic socket. Read more about this solution to the ongoing charging shortage on [page 32.](#)

We have two BP Recommends this month: the first is Kelio Ltd: industry-leading provider of integrated HRIS, Time and Attendance and Access Control solutions. The modular-based solution is a gamechanger: simplifying workforce management with onboarding, clocking in, remote working, activity against cost centres, scheduling and absence management all in one place. Read more on [page 6.](#)

Our second is Westley Lansdowne Safety Consultancy: the Leicestershire-based company provides H&S advice to SME's. With targeted expertise in complex safety in applications such as defence, aerospace and transport, the company provides robust support within occupational safety. Find out more about Safety Engineering, Expert Witness & Health & Safety on [page 17.](#)

[On page 4](#) we spotlight Davies Turner: a leading global powerhouse in the freight forwarding industry. With business booming, the company has opened a new cutting-edge multi-user fulfilment centre and logistics hub in Atherstone, Warwickshire. This facility spans across four levels, each housing 35,000 square feet of space, and boasts an impressive capacity of 20,000 pallet locations.

**News to share?**  
**Email: [liz@bestpracticeuk.com](mailto:liz@bestpracticeuk.com)**

## On the Cover

Christeys Food Hygiene wins gold medal for Sustainability.

Christeys Food Hygiene has been awarded the prestigious EcoVadis Gold Medal for its commitment to sustainability and responsible business practices.



[See page 01](#)



[Download our iOS app here](#)



# Simple and inexpensive compliance solutions tailored to any industry.

CheckedSafe provide compliance services across commercial & plant hire businesses, utilities companies, and many other service sectors that are monitored for compliance.

## Vehicle Compliance

The vehicle compliance system for all fleets with paperless defect reporting and office portal.

- ✓ Driver's app
- ✓ Back-office portal
- ✓ Licence checks
- ✓ DVSA compliant

## Dynamic Risk Assessment

Identify hazards, assess risk, take action, and review reports, on-site, and in real-time.

- ✓ Simple to use
- ✓ Remote use enables
- ✓ Pay-as-you-go
- ✓ OCR technology

## Lone Worker

The smart way to protect lone workers with visibility of all your team members in the hub.

- ✓ SOS red alerts
- ✓ Worker down alerts
- ✓ Welfare checks
- ✓ Group notifications

Try free for 30 days at  
[checkedsafe.com](https://checkedsafe.com)





# Leading the way towards sustainable logistics

Davies Turner is a well-established freight forwarding and logistics company based in the United Kingdom. Founded in 1870, Davies Turner has a long history of providing transportation and logistics services, making it one of the oldest independent freight forwarding companies in the UK.

Davies Turner was one of the first economic operators in Europe and has evolved to become a leading global powerhouse in the freight forwarding industry.

Davies Turner, a family-owned enterprise, boasts a network of 23 branches across the UK, several of which are equipped with expansive warehouses. Located in Coleshill, its headquarters serves as the epicentre of its operations. Recently, the company unveiled a state-of-the-art multi-user fulfilment centre and logistics hub in Atherstone, Warwickshire. This cutting-edge facility spans across four levels, each housing 35,000 square feet of space, and boasts an impressive capacity of 20,000 pallet locations. Additionally, the Rotherham site in South Yorkshire stands as a testament to the company's regional presence, featuring offices staffed by experienced professionals under the adept leadership of Branch Manager, Andrew Ford.

"We specialise in the more awkward and out of gauge shipments that our competitors might not have the same experience with. Over the years, this has included vehicles and machinery of all shapes and sizes and even small rail engines. We can help with shipping anything out of the ordinary that may need a special licence and enjoy the challenge of shipping more unusual items!"

Davies Turner is the only freight forwarder running a regular dedicated rail import service from mainland China into the UK, which is a lifeline for many UK businesses. The express freight rail service departs weekly from Xian in Central China for groupage and full load



shipments. With concerns around the slower speed of ocean shipments and high cost of air freight, rail offers a cost-effective, reliable freight service. The LCL rail freight service takes just 19-23 days from terminal-to-terminal which is on average, 70% cheaper than air freight.

In alignment with the UK Government's ambitious 2050 Net Zero targets, businesses are urged to embrace transparency regarding their annual carbon emissions. Recognising the need for sustainable practices, Davies Turner is leading the charge towards a greener future. Leveraging the efficacy of rail transportation as a more environmentally-friendly alternative to air shipments, the company is committed to reducing its carbon footprint.

For instance, consider the stark contrast in emissions: A 40-ft container laden with 20 tons of cargo generates a mere 4% of the equivalent CO<sub>2</sub> emissions when transported by rail compared to air shipment. Embracing this ethos, Davies Turner has embarked on a transformative journey, forging a partnership with Pledge to meticulously track and report all company carbon emissions.

This strategic collaboration not only underscores Davies Turner's dedication to environmental stewardship but also empowers clients with a tangible means of quantifying and addressing carbon emissions across international supply chains. By embracing such initiatives, the company and its clientele are poised to make significant strides towards achieving Scope 3 emission targets and fostering a more sustainable future.

With the ongoing conflict in Ukraine, disrupted shipping market in the Red Sea and Panama Canal, and sporadic port strikes, many businesses have faced huge shipping delays over recent months.

"With many volatile hot spots around the world currently, we monitor situations closely on behalf of our customers. Having a regular Chinese rail service that navigates deftly round the Red Sea Shipping crisis, keeps supply chains running across the world. To reiterate this point, last December a customer asked to trial a rail shipment with us from Shanghai to the UK, alongside a pre-existing ocean shipment from the same route with a different company. The results were conclusive: the rail shipment took 18 days terminal-to-door, whereas the ocean shipment took 45 days and also ran over the estimated time schedule," said Andrew.

Davies Turner has built a strong reputation as a trusted partner for businesses seeking efficient and cost-effective logistics solutions in the UK and beyond. With a focus on sustainability, and its reliable and trusted customer service, it comes as no surprise that Davies Turner was named Number One Logistics Service Provider by Logistics Manager Publication in December 2023, in its annual list of the Top 50 UK logistics service providers. One of the key metrics for this decision was the 74.4% increase in turnover for the financial year, ending in 2022, with a record turnover of £350.6 million. Alongside the exclusive new opening of the £40 million state-of-the-art logistics hub in Atherstone, this is a very exciting time for Davies Turner.

**For all Air, Sea, Rail and Road freight quotations and further information, please see the details below:**  
**T 01709 529709**  
[rotherhamsales@daviesturner.co.uk](mailto:rotherhamsales@daviesturner.co.uk)  
[www.daviesturner.com/specialist/rotherham-specialists](http://www.daviesturner.com/specialist/rotherham-specialists)



# United in one mission to create breakthrough products that enable and empower the supply chains of the world

United In One Mission To Create Breakthrough Products That Enable And Empower The Supply Chains Of The World

In this issue, Best Practice highlights SmartFreight, a comprehensive system that allows you to utilise your own freight rates with your preferred transport providers. This platform unifies multiple carriers, providing a streamlined solution for managing all your shipping needs in one place.

Originally founded in 1997 in Australia, SmartFreight has since been acquired by Wisetech Global in 2018. Over the years SmartFreight has gone from strength to strength, and now operates in Australia, New Zealand, South Africa, and Europe, with its European office in Manchester.

Gavin Warwick is the European Partnership Manager at SmartFreight and explained in detail how SmartFreight works.

"SmartFreight is a last-mile carrier management system (CMS) with added functionality for managing client vehicle fleets and tracking self-delivered goods. It integrates with a company's ERP or WMS, accessing over 650 carriers to automate carrier selection and print compliant labels. Carrier choice is optimised for cost or speed and can be tailored using business rules based

on geography, product, or consignment attributes like value, weight, or hazardous materials. Additionally, SmartFreight offers custom post-shipping solutions, including tracking and returns portals, and features robust reporting capabilities with a carrier invoice reconciliation module."

SmartFreight specifies mainly in business software with a focus on providing solutions particularly to the supply chain sector. Its solutions are used by companies across various sectors, including manufacturing, distribution, eCommerce, wholesale, and 3PL. Typically, its customers have at least one distribution centre, use multiple third-party carriers, or may have their own vehicles, and ship a significant number of parcels or pallets.

"These businesses need a solution to manage various shipping rules and generate the correct carrier labels.

The more complex the distribution operations, the greater the order, benefit, and value their solution provides," stated Gavin.

Constant changes within businesses and environments are inevitable but to thrive and succeed a company must be flexible, responsive and willing to adopt new ways of working in order to enhance overall customer satisfaction.

Gavin said, "There is constant change in not just our business but the environment in which we operate which makes for an exciting and dynamic work place. The acquisition by Wisetech Global is providing a more global outlook to what we do and consequently to the opportunities we have available to us. Our competition is wide, varied and extensive but rather than looking over my shoulder I prefer to look ahead, focus on our customers and their needs which in turn allows us to deliver meaningful solutions to our customer base and be an attractive proposition to new customers."

In closing, we asked Gavin what the future holds for the company. He responded:

"The plan for the future is quite simple as far as I am concerned which is to continue to build and develop our solutions and to grow our customer base and business. We exhibit at 3-4 focused logistics and technology shows each year in the UK which provides us with fantastic opportunities to meet businesses looking for the type of solution we can bring to bear. Our next exhibition is the eCommerce Expo at the ExCel in London on the 18-19th of September 2024."

**Contact**  
T 0333 996 2218  
<https://smartfreight.com>

**SmartFreight**  
Brighter Shipping Software  
WISETECH GLOBAL GROUP

*Simplify your shipping with SmartFreight.*

SmartFreight automates the management of product shipping and tracking. Our Freight Management Solution lets you manage multiple carriers as if they were one and gives you visibility of your own fleet, all on one system.

We make it easy to choose between multiple shipping options. You can optimize your last mile philosophy based on best rate, fastest route or least environmental impact.

- Efficiently manage your own fleet of vehicles
- Compare own fleet vs carrier delivery for hybrid last mile systems
- Track & Trace across multiple carriers on a single branded portal

Whether you are focused on shipping costs, customer service or environmental impact, SmartFreight lets you customise your shipping options to your shipping needs.

[www.smartfreight.com](http://www.smartfreight.com)

# Global Solutions

In this issue our BP Recommends goes to Kelio Ltd: industry-leading provider of integrated HRIS, Time and Attendance and Access Control solutions.

With expertise spanning over 35 years, Kelio Ltd offers comprehensive and modular based solution simplifying workforce management with all of the data in one place to underpin internal processes, such as onboarding, clocking in, remote working, activity against cost centres, scheduling and absence management.

Kelio UK is part of six subsidiaries across Europe, the latest of which is Kelio's new team in Germany. Having this new team

enables Kelio to support more and more customers locally and to provide a Pan-European offering, which is available in 13 languages. Furthermore, in addition to the offices across Europe, Kelio also have 60 partners worldwide who can implement the Kelio Workforce Management Solution and tailored to the needs of each customer.

Kelio relocated to a new, modern office in Hemel Hempstead, Hertfordshire last Summer and enjoy an open-plan working space, with sound-proofed meeting room and social area for staff. Making the decision to buy the new office, rather than rent it, signals a long term move for the company.

"We are going to bring about new functionality for our HR platform. We have a good existing range with features such as certification and onboarding, and we will be developing it further in the next version release, such as the inclusion of expenses and application tracking. At the CIPD Festival of Work and the Food and Drink Expo this year, we met many of our customers following the release of our new HR features. It was also a good opportunity to inform

# Kelio

GLOBAL WORK-LIFE SOLUTIONS

the attendees about the functionality we now have to offer; providing an all-encompassing solution.

Many providers only have HR or Time and Attendance or Access Control, whereas Kelio provide a solution combining HR as well as both Time and Attendance and Access Control. We make an all-encompassing solution from the point of onboarding and throughout the employee's journey offering an A to Z of services.

As of last April, the updated Flexible Working Act came into effect; everyone now has the ability to make two flexible working requests in a year. At Kelio, we offer customers the facility to manage their workforce to mirror the enhanced flexibility that the company wants to offer," outlined Richard Manby, Managing Director for Kelio Ltd.

Contact  
[www.kelio.co.uk](http://www.kelio.co.uk)



# Kelio

GLOBAL WORK-LIFE SOLUTIONS

## Workforce Management and Access Control in one solution!

**Workforce scheduling** based on skills and projects

**Clocking in systems** for different environments

**Cost centre tracking** for specific projects

**Automated alerts and attendance reviews** at a glance

**Automatic building access reports**



[www.kelio.co.uk](http://www.kelio.co.uk) | 01442 418800 | [enquiries@kelio.co.uk](mailto:enquiries@kelio.co.uk)



# Cirrus Research plc



Cirrus Research plc; leaders in noise monitoring for more than 50 years Cirrus Research plc is a globally recognised leader in the design, manufacture, and distribution of noise and vibration monitoring solutions.

Since its establishment, Cirrus Research has committed itself to providing innovative and reliable products and services that address the evolving needs of monitoring and measuring varying impacts across a plethora of sectors.

This dedication has positioned Cirrus Research as a pivotal player in promoting health, safety and environmental sustainability worldwide.

The cornerstone of Cirrus Research's operations is its extensive products range, which encompasses not only sound level meters, noise dosimeters and vibration meters, but has recently been extended to include remote monitoring solutions and gas and particulate monitoring

tools. These products are designed with the end-user in mind, incorporating advanced technology to ensure accuracy, durability, and ease of use.



Cirrus Research's commitment to quality is evident in its adherence to international standards, ensuring that its products not only meet but exceed the rigorous requirements set forth by regulatory bodies.

Contact  
[www.cirrusresearch.com](http://www.cirrusresearch.com)



## Revo Hand-Arm Vibration Meter

Your Precision Partner for Hand-Arm Vibration Safety



Measurements are accurate and in accordance with Regulations



Stores up to 10,000 measurements and up to 1,000 FFT measurements



User-friendly and intuitive design making this device easy-to-use



[www.cirrusresearch.com](http://www.cirrusresearch.com)    [sales@cirrusresearch.com](mailto:sales@cirrusresearch.com)    +44 1723 891655



# One AZM40 for all situations

*It couldn't be more flexible: solenoid interlock now with new function*

The world's smallest electronic solenoid interlock AZM40 now offers even more versatile application options with new accessories and new features.

With dimensions of 119.5 x 40 x 20mm, it is particularly suitable for small safety gates or maintenance hatches and confined installation spaces. Despite its compact design, the AZM40 achieves a remarkable locking force of 2,000 N.

With the new lockout tag, the AZM40 can now also be used for larger, accessible machines and systems. Service staff can attach a lock to the lockout tag when entering the danger zone. This means that the door of the safety guard cannot be closed, and unintentional start-up of the machine is prevented.



In addition, the new versions of the AZM40 solenoid interlock can be extended with an emergency exit or emergency release. Two different versions – with lever or push-button – are available. The lever is available both as an emergency exit and as an emergency release and can be mounted directly on the AZM40. The push button is also available as an escape release or emergency release. Its similarity to an emergency stop button makes it intuitive to operate. The emergency exit ensures that any trapped persons can free themselves from the machine area. The emergency release is used to ensure that the danger zone in a machine can be reached quickly in an emergency – e.g. in the event of a fire.

The new 'inner values' of the AZM include the addition of the high degree of protection IP69 and the temperature range of -20°C to +55°C, which open up additional application possibilities.

Another advantage is the long service life with now 500,000 switching cycles (actuator cycles) and 1,000,000 locking cycles.

The bistable interlock principle of the AZM40 is also sustainable, with the advantage of permanently lower power consumption. Compared to monostable solenoid interlocks, more than 50% of the power consumption can



be saved. A further advantage is the added safety: even in the event of a power failure, the safety door remains securely closed during hazardous run-on movements.

Thanks to the 180-degree angle flexibility, the actuator can approach the AZM40 continuously so that the interlock can also be used on flaps that do not close at a 90 degree angle or that open upwards at a 45 degree angle. The angle flexibility ensures that the interlock can be easily installed even in confined and difficult-to-access locations.

The AZM40 can be easily mounted on standard 40mm profiles with no overhang. For other profile system widths (20mm, 30mm, 45mm, 50mm and 60mm), a set of two universal mounting plates can be used for the AZM40 and actuator. This ensures quick and cost effective installation for a wide range of profile system widths.

Contact [www.schmersal.com/en/home](http://www.schmersal.com/en/home)

## Market leaders in machinery safety engineering



Marked as one of our top exhibitors at The Health & Safety Event 2022, Safety Systems Technology UK Ltd.'s (SST) is a market leader in the integration of mechanical and electrical safety systems that are designed to provide safe, user-friendly and cost-effective systems.

As a company, SST embody professionalism and a level of unrivalled expertise that spans across a wide range of sectors. It has the capabilities to provide a complete solution for the design, installation and commissioning for a vast number of industries including heavy engineering to nuclear, steel making, pharma, paper and board, automotive, food and drink, and process.

SST's guarding systems include both modular and bespoke solutions designed for easy installation and removal as well as easy removal for downtime. All its guarding systems are in accordance with EN Standards and are CE

Marked accordingly and issued with a Declaration of conformity.

For perimeter guarding, it will be designed with the most appropriate access door system from the wide range that is available. This includes hinged single or double doors, sliding doors with top or bottom track, and trackless cantilevered doors for crane or forklift access.

SST design everything around the customers wants and requirements. Its Bespoke guarding solutions are particular designed to EN Standards but with a practical application. SST's guarding design has years of experience across perimeter, local guarding and fixed access. Whether you're looking for an off-the-shelf or bespoke solution, SST can design and fabricate to your needs.

For more information, please see below; <https://www.safetysys.co.uk>



**SAFETY SYSTEMS TECHNOLOGY**  
Machinery Safety Solutions

Machine Guarding design, fabrication & installation

Safety Related Control System design, build & installation

POWER & CE/UKCA Consultancy

Light Curtain Testing

EN60204-1 Testing



T 08450 750008 | E [info@safetysys.co.uk](mailto:info@safetysys.co.uk)  
[www.safetysys.co.uk](http://www.safetysys.co.uk)



# How pallet live storage keeps grocery store shelves supplied

An innovative Pallet Live Storage installation can play a key role in supporting grocery retailers as they strive for market leading growth, according to Edward Hutchison, Managing Director of BITO Storage Systems.

Providing up to 50% more storage capacity than traditional racking on the same footprint, a Pallet Live Storage (PLS) system can contribute significantly to accommodating sufficient stock to help grocery retailers meet growing demand.

Supporting a retailer's need to maintain customer service in tandem with achieving sales growth is one of the biggest challenges placed on a distribution centres (DC), particularly when it comes to handling the sheer volumes involved and fast turnaround required by everyday bulk stock lines, such as soft drinks.

Pressure intensifies when these lines experience peaks, such as during a hot summer – particularly in large cities or on the coast. If one store runs out of soft drinks on a very hot day, there's a good chance that others in the region will experience a similar issue. All will want more but storage limitations mean there's a chance that not every store will get the amount they require, which will impact negatively on the grocery retailer's level of customer service.

Maximising the amount of storage that can fit within the constraints of a DC, to provide

# BITO

## STORAGE SYSTEMS

efficient order fulfilment for retail stores, will help to avoid such situations. For those grocery DCs that need greater flexibility to meet a variety of demands from customers within a limited space, PLS offers a dense storage and order picking system that contributes to innovative, efficient and agile grocery logistics operations. On a relatively small footprint, pallets can be located 'in the air' on several levels of inclined roller lanes, with delivery lanes for pallet loads of bulk stock lines – such as soft drinks – on the ground floor. This provides dense storage and rapid access to orders.

The flexibility in such a design allows products that need to be sent immediately to stores

to be picked directly from the flow lane and transported to Goods Out. If the ground floor delivery lanes are getting close to empty, then stock stored in the lanes above can be brought down and pushed through to the other side of the lane for order pickers to continue their pick.

Operating on the FIFO (First In First Out) principle, PLS ensures product rotation, which is important for grocery store replenishment, ensuring the first product sorted by the 'best before' date is picked. A further benefit is that PLS can accommodate seasonal items on the flow lanes in the upper levels, allowing the grocery DC to take advantage of quiet time to get those products out to stores early.

Gaining the capacity to stock items in sufficient quantities to avoid running out, thus allowing the DC to react on customer demands quickly and deliver straightaway irrespective of the amount ordered by a store, even when bulk products a hit, peak makes the investment in PLS well worth it. A PLS system supplier with an experienced team of experts should be able to work closely with the client to develop competitively priced, customised solutions and work around existing operations to deliver projects on time.

For further information on pallet live storage, please visit: [www.bitosystems.com](http://www.bitosystems.com)

# Looking for alternatives to decrease lead times between China and Europe?

## KERRY LOGISTICS

Kerry Logistics Sea-Air service is an end-to-end solution for your cargo, ensuring total visibility at all times. Cargo is booked at origin through our own network and handled in Dubai via our bonded facilities in Jebel Ali, offering safe handling and fast transhipment.

Balancing affordability and the need for prompt delivery, our solution offers a transit time of 16 to 21+ days from China Seaports to EU Airports. We also offer a service from main ports in South East Asia to EU destinations.

The ongoing crisis in the Red Sea is causing significant issues to global supply chains. With many carriers rerouting around the Cape of Good Hope, transit times have increased.

The current disruptions are causing bottlenecks in global supply chains and concerns are being raised about future equipment availability, the longer the situation continues.

For more information about how working with Kerry Logistics can add value to your supply chain, or to learn about our multi modal solutions, get in touch.

Contact  
T 0161 873 8777  
[contact.uk@kerrylogistics.com](mailto:contact.uk@kerrylogistics.com)  
<https://www.kerrylogistics.com>

MANCHESTER, HEATHROW,  
GLASGOW, BRADFORD,  
DARTFORD, BIRMINGHAM,  
NORTHAMPTON





**CML**

INNOVATIVE TECHNOLOGIES

WHERE INNOVATION COMES TO LIGHT



## High Quality Panel Mount Indicators

CML IT continues to be the number one supplier of panel mount indicators, LED lamp replacements and LED tower lamp solutions.

PMI highlights include:

- Plastic and metal bezels with a wide range of options in stock.
- IP40 and IP67 ratings.
- Development of custom solutions.
- UK manufacturing facility.



*Fast supply chain & global distribution*



Contact our Customer Services department to discuss your requirements today.

Visit our website at: [www.cml-it.com](http://www.cml-it.com)

CML Innovative Technologies Ltd,  
69/70 Eastern Way, Bury St Edmunds,  
Suffolk, IP32 7AB, United Kingdom  
Tel: +44 (0)1284 714700 email:  
[uksales@cml-it.com](mailto:uksales@cml-it.com)



# Illuminating Safety

## Wireless Bluetooth Networked Lighting Control in Hazardous Areas

In hazardous environments such as oil refineries, chemical plants, and mining operations, the advent of wireless Bluetooth networked lighting control represents a significant leap in safety and efficiency. These settings demand rigorous safety standards and reliable technology to ensure worker well-being and asset protection. Wireless Bluetooth lighting control offers a robust solution that enhances both safety and operational efficiency.

Traditional lighting systems in hazardous areas rely on hardwired connections, which can be cumbersome and costly to install and maintain. Wireless Bluetooth technology eliminates the need for extensive wiring, reducing installation time and costs. Crucially, it minimizes the risk of electrical sparks – a vital consideration in environments with flammable gases or dust.

The ability to remotely monitor and control lighting systems is a primary benefit of Bluetooth networked lighting. In hazardous areas, workers can adjust lighting levels, test emergency lighting or diagnose issues without entering dangerous zones. This enhances safety and improves operational efficiency through rapid adjustments and maintenance. Bluetooth networked lighting systems can



Energy efficiency is another advantage. Bluetooth lighting systems operate only when necessary, reducing energy consumption and heat generation critical in hazardous areas where temperature control is vital.

While implementing Bluetooth networked lighting in hazardous areas must address challenges like robust cybersecurity and device compatibility, the potential benefits are substantial. By enhancing safety, reducing costs, and improving operational efficiency, wireless Bluetooth networked lighting control lights the way toward safer, more efficient industrial environments.

For more information please contact STL International Ltd ([SMARTEXLED@stl-int.co.uk](mailto:SMARTEXLED@stl-int.co.uk)).



integrate with other safety and monitoring systems. For example, in the event of a gas leak or fire, the lighting system can respond by increasing illumination to guide evacuation routes or flashing lights to signal an emergency. This integration ensures a cohesive safety approach where lighting actively supports emergency protocols.





**The Spotlight is on  
Watsons Anodising Ltd**

**WATSONS ANODISING LTD IS A LEADING MANUFACTURER OF BESPOKE ASSET TAGS, LABELS, STICKERS, AND CONTROL PANELS SPECIFICALLY DESIGNED FOR THE FOOD AND DRINKS INDUSTRY. WITH YEARS OF EXPERIENCE IN THE INDUSTRY, WE UNDERSTAND THE UNIQUE REQUIREMENTS AND REGULATIONS THAT ARE NECESSARY FOR PRODUCTS USED IN THE FOOD AND DRINKS SECTOR.**

**OUR ASSET TAGS ARE DURABLE AND CAN WITHSTAND HARSH ENVIRONMENTS, ENSURING THAT YOUR ASSETS ARE PROPERLY IDENTIFIED AND TRACKED. OUR LABELS AND STICKERS ARE DESIGNED TO RESIST MOISTURE AND CHEMICALS COMMONLY FOUND IN FOOD AND BEVERAGE PROCESSING ENVIRONMENTS.**

**IN ADDITION, OUR CONTROL PANELS ARE CUSTOM-DESIGNED TO MEET THE SPECIFIC NEEDS OF YOUR FACILITY, PROVIDING ACCURATE AND RELIABLE CONTROL OVER YOUR MACHINERY AND PROCESSES.**

**AT WATSONS ANODISING LTD, WE ARE COMMITTED TO PROVIDING HIGH-QUALITY, RELIABLE PRODUCTS THAT MEET THE STRINGENT REQUIREMENTS OF THE FOOD AND DRINKS INDUSTRY. CONTACT US TODAY TO DISCUSS YOUR SPECIFIC NEEDS AND HOW WE CAN HELP YOU WITH YOUR ASSET TAGGING, LABELING, AND CONTROL PANEL REQUIREMENTS**

CONTACT US TODAY  
01226 748524  
[sales@watsonsanodising.co.uk](mailto:sales@watsonsanodising.co.uk)  
[www.watsonsanodising.co.uk](http://www.watsonsanodising.co.uk)



**SAFE answers to  
HAZARDOUS questions**



Microwave sensors for zone 1/21  
High performance LED lighting:

- In excess of 16,000 lumen in a 5ft linear luminaire
- Flexible high bay lighting with multiple beam optics and up to 43,634 lumen
- Recessed luminaires for Cleanrooms up to 25,700 lumen
- Silicone free options for Spray Booth applications
- Integral microwave sensors for zone 2/22 luminaires
- Dimmable and self-testing DALI drivers and converters



STL International Ltd  
+44 (0)1622 749633  
[www.stl-int.co.uk](http://www.stl-int.co.uk)





# *Continuous Remote Monitoring*



**Three years time storage**  
3 years rolling data retention



**Live dashboards**  
Create real-time dashboards to analyze data and control devices



**Events engine**  
Keep operators on-the-ball and informed



**Synthetic Variables**  
Transform raw data into insights



**User management**  
Build applications to best fit the operator's needs

---

**Interface Force Measurements Ltd**

Ground Floor, Unit 19, Duke's Ride, Wellington Business Park  
Crowthorne, Berkshire RG45 6LS

Tel: +44 (0)1344 776666 | Email: [info@interface.uk.com](mailto:info@interface.uk.com) | [www.interface.uk.com](http://www.interface.uk.com)



# SEMOTA:

## sense, monitor, trigger, act

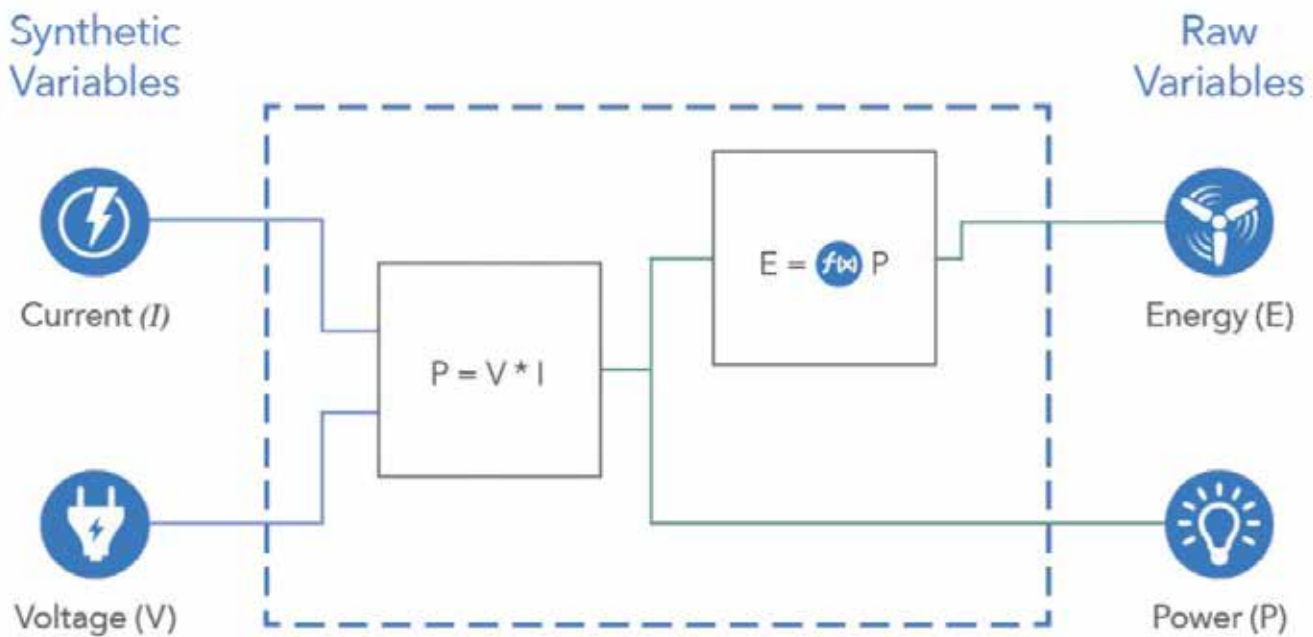

## The new remote monitoring solution from interface force



SEMOTA is a hardware and software solution with a web-based application that enables the remote monitoring of any load cell, force, torque or pressure sensor, using our Wi-Fi enabled hardware.

SEMOTA Continuous Remote Monitoring provides dynamic dashboard views of your events, analysis and device control. Information can be captured and stored for review and in depth analysis. Linkage to common messaging systems deliver live alerts for device management. Tailor and build applications to suit your needs and devices. Read more below, then complete the form and we'll arrange a demonstration.

### THREE YEARS STORAGE

Whether your data is needed every day or every few seconds, SEMOTA is optimised to receive, compute, and return millions of data points across the globe.

### LIVE DASHBOARDS

Using SEMOTA point-and-click application development tools, create real-time dashboards to analyse data and control devices. Visualize data with SEMOTA stock graphs, charts, tables, indicators, maps, metrics, and control widgets or develop your own using the HTML canvas and your own code. Share your data through public links, or by embedding dashboards into custom web applications.

### EVENTS ENGINE

Add conditional and complex business logic to your hardware with triggered webhooks for M2M communication, and SMS, Email, Telegram, and Slack alerts to keep operators on-the-ball and informed.

### SYNTHETIC VARIABLES

Transform raw data into insights with Synthetic Variables that compute complex math formulas and statistical expressions.

### USER MANAGEMENT

With SEMOTA cloud software, you can build applications to best fit the operator's needs. SEMOTA administrators can configure permissions and restrictions to any end user or operator who interacts with dashboards, devices, and/or events. Need a user to be able to oversee multiple organisations? Not a problem. You can optionally add more users or organisations to your account and we can configure your users to best suit your application.

### Contact

T +44 (0)1344 776666

F +44 (0)1344 774765

info@interface.uk.com

www.interface.uk.com



# How can a Small Game-Changing Pump Revolutionise the Beauty Industry?



The world of beauty and body care is constantly evolving, seeking new methods and manufacturing techniques to improve efficiencies, enhance the customer experience, save single-use packaging waste, and cater to individual customer needs. In this blog, we'll explore how Quantex's game-changing pump technology can provide a radical new hygienic, easy-to-use, cost-saving and sustainable pumping solution that could impact the beauty industry in a number of ways.

## Transferring Thick and Viscous Solutions

One of the biggest challenges the beauty industry faces is understanding and being able to handle highly viscous products like thick hair conditioners, face creams, and body butters.

Traditional peristaltic pumps struggle with these thick products because they can't cope with the pressure and flow rate needed to propel the produce out of its primary container and into its intended location. This failure can lead to manufacturing inconsistencies and inefficiencies such as a poor quality product or an inaccurate quantity ready for sale. Quantex, however, has developed a range of pumps specifically designed to handle thick and viscous materials with ease by using a positive displacement rotary action, with high vacuum and high-pressure capability.

## Accurate Dosing: A Drop of Perfection

The beauty industry is full of expensive and luscious products that require careful handling and a delicate balance of ingredients to make their final solution. If these expensive ingredients aren't accurately dosed or mixed at the right stage, the product composition will be inaccurate and could be costly to rectify, especially when produced in mass volumes.

However, dispensing the perfect amount of product is made far easier with Quantex pumps due to their unique method of precision pumping. The fixed displacement pump design principle consists of the volume of an individual cavity of liquid product carried on the rotor constrained within the rigid pump housing. This ensures that an accurate volume of liquid is displaced for each revolution over a wide range of flowrates, pressures, viscosities and temperatures.

One way to revolutionise the beauty industry is to mix these ingredients at the point of dispense. An example of this could be a body cream manufacturer who needs to mix small but highly accurate fragrances into the final solution to create a range of scented body lotions. The base mixture remains the same, but the additional scent that's added at the end needs to be perfectly balanced to create the right notes and fragrance. This can be achieved with Quantex's fixed displacement rotary action and in-pump dilution and mixing.

**Hygienic, Easy-to-Use, Compact Dispensing**  
Another unique attribute to Quantex pumps

is that they are designed to be recyclable and for single-pack-use. The pump is attached directly to the product's primary container and dispensed directly from the container through the pump, therefore no product needs to travel through fixed machinery. Products can easily be swapped in and out of any channel with one click, and without cross-contamination. With only a standard motor-drive and motor controller required, dispensing machinery can be highly compact and low cost. Since the pumps are replaced with each new pack, no calibration is required which creates a very low-maintenance system.

## Colour on Demand: A Customised Experience

Beauty product companies are always looking for ways to stand out, and one way to do so is to provide more bespoke choices for customers. The world is full of different bodies and unique looks, so how can we provide customisable products?

Make-up brands are only just starting to tap into the customisation market, such as No 7 who provides onsite or virtual 'colour-matching' services that will scan the customer's skin colour, pick up the tone of pigments on the skin and then suggest the closest matching foundation they have out of their pre-made solutions. This bespoke service could be augmented with the aid of Quantex pumps; by accurately mixing the colour pigments into base products within a dispensing machine at the point of sale. This can produce the exact unique shade/formula to match the skin-type on demand and consumers will benefit from their own special uniquely-colour-matched foundation.

## Beyond the Bottle: Refill and Sustainability

As the world becomes increasingly aware of sustainability and the impact of excessive packaging, the beauty industry and its customers are finding ways to reduce their waste. Zoe Boikou, CEO and founder of Zoeva notes that in 2024 "consumers will have an even stronger focus on products that are reusable and recyclable." As one of the biggest contributors to waste, "the beauty industry will need to continue to innovate when it comes to the life-cycle of products" quotes Forbes.

Companies such as The Body Shop and Lush are already paving the way for this. Lush, acknowledges that in 2022, its customers returned and refilled over 720,000 items of Lush packaging to their shops for product refill and even offers customers incentives through its 'Bring It Back recycling scheme' to encourage recycling and refilling.

Quantex pumps can align perfectly with the growing trend of refillable beauty products and help brands integrate cost-effective, hygienic and easy-to-use refill stations within their retail environments. Ideal for handling thick solutions and providing accurate dosing, Quantex pumps are a key enabler to help the beauty industry reduce packaging waste.

## Reduced Transportation Costs and Carbon Footprint

As mentioned in a previous blog 'How to dispense highly concentrated solutions to reduce your carbon footprint' we discussed the benefits of working with highly concentrated liquids and how this means products can be shipped in smaller, more

concentrated versions, resulting in a reduction in transportation costs. There are many beauty products that lend themselves to higher concentrated versions: for example:

- ▲ Serums
- ▲ Toners
- ▲ Perfumes
- ▲ Shampoo
- ▲ Nail Polish Remover
- ▲ Hand creams
- ▲ Conditioner

Certain products such as hand creams and conditioners could be available with various thickness options depending on the amount of water added to the concentrated base product.

Quantex pumps are known for working with far higher concentrations than most pumps due to the pump's unique high vacuum and high-pressure capability – and using In-Pump Dilution versions open up the possibilities for using highly concentrated products to save brand's shipping costs and carbon footprints.

## Handling Expensive Ingredients in Small Quantities

The beauty industry is known for providing solutions in compact packaging. Dispensing these products in such small quantities into mini containers can be tricky, but Quantex Low-Flow and Microdosing Pumps are perfect for handling precise doses of solutions into small and narrow containers or pots.

## Summary

Quantex pumps are poised to revolutionise the beauty industry in a number of exciting ways... Their ability to handle high-viscosity products, dispense precisely, hygienically, and without mess are all compelling attributes – but considering, in addition, that they render more compact and low-cost dispensers, that are easy-to-use and maintain, and that they can dilute concentrates in-pump, and you have a number of exciting opportunities to move the beauty industry forward for the better.

## For example to enable:

- ▲ Cost effective in-store refill machines to save single-use packaging waste
- ▲ Future technologies like facial-scanning bespoke make-up colour-mixing to provide consumers with more choice and encourage brand loyalty
- ▲ Dispensing concentrated products that take water out of the distribution channel and lower shipping costs and carbon emissions.

In conclusion, Quantex is set to pave the way for a more personalised, efficient, and sustainable future for beauty. So, get ready to witness some transformations, where Quantex pumps become the silent heroes behind some radical changes for the better for the beauty industry.

## You can learn more about our pump range here:

- ▲ Microdosing Pump
- ▲ Low Flow Pump Range
- ▲ Bag-In-Box Pump Range
- ▲ High Flow Pump Range

**If you'd like to learn more or discuss how a Quantex pump could work for you, please contact:**

**T +49 (2065) 89205-0.**  
[quantex-info@psgdoover.com](mailto:quantex-info@psgdoover.com)



# Where **ENGINEERING** meets **OPPORTUNITY**

We specialise in **CONNECTING** skilled contractors with manufacturing businesses.

**Our platform seamlessly BRIDGES THE GAP, facilitating collaborations that enhance project efficiency and quality.**

With a focus on streamlining communication and fostering valuable partnerships, **CONTRACTORS 4 INDUSTRY LTD** is the go-to hub for engineering professionals and manufacturing enterprises seeking successful collaborations.

#### **ADVANTAGES FOR INDUSTRIAL ENGINEERING CONTRACTORS:**

- HIGH QUALITY LEADS • TARGETED AUDIENCES
- DATA-DRIVEN INSIGHTS • EFFICIENCY
- ENHANCED REPUTATION • COST-EFFECTIVE MARKETING

#### **ADVANTAGES FOR INDUSTRIAL PROJECT/ENGINEERING MANAGERS:**

- VERIFIED EXPERTISE • ENHANCED PRODUCTIVITY
- SPECIALISED NETWORK • STREAMLINED PROCESS
- COST-EFFICIENCY • FLEXIBILITY



**Contractors4industry**

T: 07880474762

E: [info@contractors4industry.co.uk](mailto:info@contractors4industry.co.uk)

W: [contractors4industry.co.uk](http://contractors4industry.co.uk)



# Measurably better Chemiluminescence analysers

Nitrogen Oxides (NO<sub>x</sub>) are chief villains in the battle for climate control; belonging to a family of gases that are formed during the combustion of fossil fuels. When Nitric Oxide (NO) reacts with other gases, for example with Ozone, it forms Nitrogen Dioxide (NO<sub>2</sub>), which is considered highly toxic to human health.

The reaction with Ozone is also an indicator for why Nitric Oxide (NO) is considered a climate active gas, that interacts with Earth's protective Ozone layer. Human exposure to high levels of Nitrogen Dioxide (NO<sub>2</sub>), but also Nitric Oxide (NO) can cause airway inflammation, susceptibility to allergens and exacerbate pre-existing lung or heart conditions.

Nitric Oxide (NO) is a biological marker of inflammation and is also produced by cells involved in the inflammation process. It is typically used to diagnose allergic/eosinophilic asthma. Legal ambient air limit value (annual average value for the European Union) for Nitrogen Dioxide (NO<sub>2</sub>) concentrations is 40µg/m<sup>3</sup>. Maximum occupational exposure limit is 950µg/m<sup>3</sup>. Indoor air limit value for maximum exposure is 250µg/m<sup>3</sup> but the precautionary value 80µg/m<sup>3</sup>. The WHO defines 40µg/m<sup>3</sup> as precaution limit.

The Department for Environment, Food & Rural affairs (DEFRA) has also reported soil chemistry and biodiversity changes across many UK habitats, through gas (dry deposition) and precipitation (wet deposition.) Anthropogenic Nitrogen Oxides (NO<sub>x</sub>) influence tropospheric chemistry, which directly cause photochemical smog and concentrated levels of urban ozone.

ECO PHYSICS AG offer world-leading measurements of Nitrogen Oxide (NO<sub>x</sub>), through trailblazing chemiluminescence analysers. These innovative analytical solutions are unprecedented in speed and sensitivity, with a cutting-edge range of sensitivities from 1% down to 1 ppt (part per trillion). Chemiluminescence Analysers use a unique thermally-stabilised semiconductor photodiode, to measure light intensity produced by reactions between Nitric Oxide (NO) with Ozone (O<sub>3</sub>). The light intensity correlates to the proportion of Nitric Oxide (NO<sub>x</sub>) converted to Nitrogen Dioxide (NO<sub>2</sub>) by the reaction.

We caught up with Dr Grischa Peter Feuersänger, Head of Sales & Marketing, to find out more about ECO PHYSICS, "ECO PHYSICS was founded in 1990



perfected analytical technique in speed and sensitivity. Today we are proud to claim world leadership in the fastest and most sensitive chemiluminescence analysers and the broadest commercially available range."

This Swiss-based innovative company has EN ISO 9001: 2015 quality management and EN ISO 13485: 2016 medical devices-compliance, offering quality assurance to customers across many industries. There is a new range of gas analysers and boxed set gas analysers available: nCLD AL, nCLD AL2, nCLD AL3/8555, nCLD EL and nCLD EL2.

through a management buy-out, by co-founders Dr Matthias Kutter and Dr Werner Moser and we now operate from our base in Duernten, Switzerland. We offer innovative analytical solutions for measurement tasks in the fields of environment, health and process control. With our interdisciplinary research and development team, we are delivering customer-oriented and tailor-made products and services. The initial know-how focus was centred on the principle of the chemiluminescence, thus developing and manufacturing analysers for the ambient pollution and emissions. We have

The nCLD AL3/8555 is a next-generational modular gas analyser, offering state-of-the-art simultaneous measurements of NO, NO<sub>2</sub>, NO<sub>x</sub>, NH<sub>3</sub> and NO<sub>x</sub>-Amines. Even lower detection limits can be detected through the newly designed reaction chamber, enhanced gas flow paths, improved pressure and temperature stability. This analyser is adaptable to non-standardised applications, with the unit calibration running smoothly on an automated basis.

T +41 55 220 22 22  
info@ecophysics.com  
www.ecophysics.com

**ECO PHYSICS nCLD "Facelift" boxed solutions**  
AL, AL<sup>2</sup>, EL S, EL, EL<sup>2</sup>

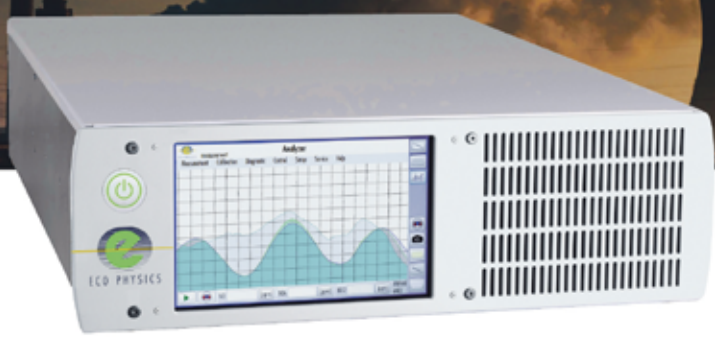

**Measurement of:**  
NO · NO<sub>2</sub> · NO<sub>x</sub>

The one- and two-channel chemiluminescence based NO<sub>x</sub> analyzers of the nCLD "Facelift" box-solution analysers detect NO, NO<sub>2</sub> and NO<sub>x</sub> at concentrations ranging from 5 ppm to 5000 ppm with minimal detection limits averaging from 0.4 ppb to 0.5 ppb. They hereby focus on two main application areas, Ambient Air (AL, <50ppm) and Emission/Process (EL, <500ppm; EL S <5'000ppm) monitoring. The one-channel nCLD AL, EL and EL S feature an external pump, while the two-channel nCLD AL2 and EL2 include an internal pump. The nCLD "Facelift" boxed solutions consist of five, fixed and preconfigured analysers. The nCLD AL (Ambient Level) and EL S/EL include a standard NO/NO<sub>x</sub> measurement, with an optional NO<sub>2</sub> add-on, while AL2 and EL2 include, due to the two-channel set-up, a standard NO<sub>2</sub> detection. Additionally, all nCLD-models are capable of a remote power down/up including a failsafe feature. nCLD AL2 and EL2 are TÜV approved, qualified according to ISO EN 14211 and 15267 1-3.

- Compact analyzer with external or integrated pump
- "Toggle mode" NO<sub>2</sub>-feature for One-Channel instruments
- Intuitive graphical user interface
- Internal data logger and status recorder
- Remote operation/control, Power DOWN/UP
- USB, HDMI, LAN/WLAN, Bluetooth, RS-232, Analog I/O

ECO PHYSICS AG · POB · CH-8635 DUERNTEN · TEL. +41 55 220 22 22 · FAX +41 55 220 22 55 · E-MAIL INFO@ECOPHYSICS.COM · WWW.ECOPHYSICS.COM



# How to make your air compressor more energy efficient

It is estimated that air compressors account for more than 10% of the total energy consumed by UK industry, but many of these are unfortunately old and inefficient.

**There are several ways to increase energy efficiency, however, when it comes to compressed air:**

First, choose a compressor with the best Specific Power – the energy efficiency rating of a compressor. Specific Power is the ratio of total energy used by the compressor and its compressed air output (at a stated pressure). The lower the Specific Power, the greater the efficiency, and the higher the energy and money savings.



Second, explore the merits of Heat Recovery. A rotary screw compressor converts 100% of the drawn electrical energy into heat. Up to 96% of this energy can be recovered. Energy costs can account for up to 80% of life-cycle costs over the lifetime of a compressor. By using heat recovery, these costs can be significantly reduced.



Up to **96%** energy reusable for heating purposes

Third, utilise energy-saving control. Some of the biggest energy savings in a system can be achieved with an air compressor master control system, which can identify wastage, make predictions and make necessary adjustments to ensure significant energy cost savings while delivering a reliable, consistent and efficient compressed air supply.

You can achieve all three of these methods with HPC KAESER compressors. With market-leading Specific Power and Heat Recovery Systems and state-of-the-art Compressed Air Management Systems via the Sigma Air Manager (SAM4.0), saving energy has never been easier with HPC KAESER compressors.

**Whether you are keen to be greener or you are a UK manufacturer looking to reduce overheads by thousands of pounds, switching to the most energy-efficient air compressors can help. Find out how much you could be saving in energy costs with our new Energy Savings Calculator: [www.hpccompressors.co.uk/calculator](http://www.hpccompressors.co.uk/calculator)**

**Can you afford NOT to upgrade to an energy efficient compressor?**

- Save 30%+ on energy bills
- Recover 96% exhaust heat
- Benefit from market-leading Specific Power
- Achieve low life cycle costs
- Trust world-class engineering
- Get more air for less energy

**HPC** | Compressed Air Systems

**KAESER COMPRESSORS** HPC Compressed Air Systems is the official U.K. partner of KAESER Compressors.

Contact an HPC KAESER specialist on 0845 4300 472 or visit [www.hpcplc.co.uk/distributor-network](http://www.hpcplc.co.uk/distributor-network)

**Westley Lansdowne**  
Safety Consultancy

We provide expert consultancy in safety management to help duty holders in businesses of all types and sizes meet their safety obligations in the most effective way possible

**OUR SERVICES**

- Safety Engineering**  
Serving highly regulated industries and applications
- Expert Witness**  
Providing expert advice on safety management matters to legal professionals working on civil claims
- Health and Safety Services**  
For businesses of all sizes

07476 245 559  
[hello@westleylansdowne.co.uk](mailto:hello@westleylansdowne.co.uk)  
45A Cross Street, Wigston, Leicestershire, LE18 1AD  
[www.westleylansdowne.co.uk](http://www.westleylansdowne.co.uk)



# British Adhesives & Sealants Association



This is BASA's 40th year of operation and we are still excelling in our mission to remain the umbrella organisation for UK adhesives and sealants manufacturers. Focussing on technical and legislative aspects and on promoting awareness of the industry and technology by providing guidance on technical and compliance issues, we create a variety of networking opportunities for members and provide a huge library of documents on the website.

BASA is the voice of the adhesives and sealants industry's and is an information source for manufacturers and suppliers. The association advocates on behalf of its

members and liaises with Government regarding legislation and keeps Members well informed of UK, EU and International proposals and initiatives.

With the growing concerns around the environment and using sustainable products and raw materials, BASA is dedicated to helping its members minimise harmful chemical usage and educate the public on the industry's drive for safer products. BASA members work hard to formulate innovative products that positively contribute to the sustainability agenda whilst maintaining performance and durability.

BASA hopes to continue to reach more potential members, looking at ways to support its manufacturers post Brexit and help them to navigate potential new legislation and trade rules.

**Contact**  
T 03302 233290  
secretary@basa.uk.com  
www.basa.uk.com

Visit the website to find out about the costs and benefits of joining the Association.



## STRONGER BONDS MAKE BETTER BUSINESS

'BASA's members support efforts to improve product efficiency and circularity to help create a more sustainable society, promoting the concepts of energy saving, material efficiency, reparability, durability and recycling.'

24 Laurel Close  
Ely, Cambridgeshire  
CB6 2BN

**03302 233290**



**www.basa.uk.com**

# Adhesives & glue guns



AdCo UK is one of the largest manufacturers of shaped hotmelt adhesives and water-based adhesives for use in packaging and product assembly markets for over 21 years, from its Head Office and manufacturing facility in Liphook Hampshire with additional distribution facilities based in Leeds UK and a network of approved distributors based throughout the UK.

As well as supplying adhesives for all requirements, AdCo supplies a wide range of specialist applicators – from Proflex industrial, heavy duty and professional glue guns to total melt, cartridge and bulk systems, we also manufacture and supply UF resins, PVA Adhesives, PU Adhesives, Tapes and much more

As part of our commitment to offer our customers the correct solution for their needs AdCo are continually investing in research and development along with new state of the art manufacturing equipment to ensure we continue to meet the ever changing needs of all types of industry.

Thanks to our unrivalled knowledge of adhesives and application techniques, our highly skilled technicians can offer a 'find and supply' service to all our customers. With a combined industry experience of over 120 years, our technicians can ensure that any bonding problem can be solved quickly and efficiently.

T 01428 751755  
enquiries@adco.co.uk  
www.adco.co.uk



## Patented Dripless Nozzle



AdCo's HD 250 NV is a true standout among industrial-grade hot melt glue guns, and a go-to tool for contractors and tradesmen in many fields of work.

The "NV" stands for "needle valve," an exclusive AdCo design feature which allows the user to lay down precise, uniform glue lines, with perfect cut-offs and no more dripping and stringing!

This exceptional quality tool sports cushion-padded grips, an easy-squeeze trigger, and a removable wire base stand which makes it easy to use in any work environment.

The 225 watt PTC heating system allows for quick heat-up times to its preset temperature of 210°C, and the ability to dispense upto 1.5 kilos of glue per hour.

**900**

Full-size 11/12mm Sticks

3 Second Set Time

AdCo's Proflex 900 is the best choice for industrial packaging applications due to its attractive price and impressive 3-second compression set time.

12mm  
15mm  
18mm  
43mm

**FEATURES & HIGHLIGHTS**

- Needle valve nozzle
- Uses 11/12mm glue sticks (35 x 300mm sticks)
- Output per hour: 1.5 kg per hour. (35 x 300mm sticks)
- Operating temp: 210°C
- 225 watt PTC heating system
- 4-minute warm-up
- Lighted ON/OFF switch
- Comfortable 4-finger trigger
- Removable stand
- 6-foot power cord
- UL Certified to ensure safety

Eliminates Stringing

Output / Hour 1.5 kilos

Retail £79.99

Patented Dripless Nozzle

Call - 01428 751 755

Proflex Formulations available ... 900 / 905 / 930 / 940 / 950 / 970 / 975 and more ...

ORDERS & INQUIRIES: AdCo UK Limited - enquiries@adco.co.uk - 01428 751755



# Using steamers to control & effectively remove bed bugs

Using Steamers to Control and effectively remove Bed Bugs Dry Steam is a highly effective method for killing bed bugs in all stages of their development if applied correctly. When using steam as a treatment, the quality and boiler temperature of the steamer is very important. As a guidance, a commercial steamer with a minimum boiler temperature of 150 degrees Celsius and 6 bar pressure or an even higher pressure should be selected – with a manual or digital steam volume control. It should be noted, however, that in this type of application it is the boiler temperature that is more important than the pressure.

The smaller type of steamer normally used to steam clothing or steamers with a boiler temperature below 150°C, will not be effective for bed bug treatment. Also don't use a carpet cleaning machine as this will virtually have no effect as Carpet cleaning machines do not reach high enough temperatures to kill bed bugs.

The OSPREYDEEPCLEAN Steam & Vac Pro is the ideal machine for this application. Dry Steam Machines work by delivering lethal temperatures to where bed bugs may be hiding. Steam is very effective when bed bugs are on the surface of items such as carpets, mattresses and can be effective up to 3-4" into fabric surfaces. In cracks and crevices, steam will kill bed bugs up to 3-8" into a gap. Use an infrared thermometer to monitor the surface temperature of the area being

treated. To effectively kill bed bugs the surface temperature should be at least 60-70 degrees Celsius (160-180°F) immediately after the steam tool has passed.

Following the manufacturer's directions for using the dry steamer (with the additional precautions) below will help you generate steam safely whilst obtaining maximum control of bed bugs.

#### Here are some additional tips to follow:

- ▲ Select a Dry Steam & Vacuum machine with a water filtration to capture the 'waste.'
- ▲ Attach a nozzle -or on flat surfaces – a carpet upholstery tool to the steam wand.
- ▲ For carpets, the floor nozzle will also work but the operator will have to move the nozzle more slowly to obtain the right temperatures and to increase the steam volume.
- ▲ Surfaces must reach a temperature range of 60-70 degrees Celsius (160-180°F). Below this, bed bugs may survive. An infrared thermometer should be used to measure surface temperatures after the wand has passed over the area being steamed. If the temperature is too low, move the wand more slowly but this may increase the risk of damage to the fabric and other materials. If the temperature is too high, move the wand faster.
- ▲ Fabric may be very slightly damp, afterwards but will quickly dry. Use the



steamer on all surfaces where you see bed bugs and areas where you think bed bugs may be hiding. You may have to repeat this procedure a couple of times as this method only provides control of bed bugs that are exposed to the heat, any bed bugs that do not come into contact with the steam will survive.

- ▲ Select the correct steam volume subject to the accessory chosen this should be set at low to medium level. Do not choose full volume as this would only blast the bedbug away but not kill them. Slowly move over the chosen area. Once completed switch on the vacuum at full level and use the steam and vacuum setting to slowly move over the same area again to collect all the 'waste.'
- ▲ Once the operator has completed 1 area/ room safely empty the waste container to drain or into a toilet and fill the waste tank with fresh water which basically is the new filter medium with HEPA filtration like efficacy. For a 'Belt and Braces' approach there is the option to spray the surfaces with an approved insecticide for residual efficacy.

For more information and guidance in choosing the correct machine call **OSPREYDEEPCLEAN** on 01242 513123 or email [sales@ospredc.com](mailto:sales@ospredc.com).

# STEAMFORCE®

Powerful Professional Dry Steam Cleaning

**De-grease Machinery**

**Sanitise Food Preparation**

### The STEAMFORCE Range

SF-Compact SF-Eco SF-ET SF-E SF-10 SF-20 SF-30/40/50

**Steam Clean Batteries**

**Environmental Cleaning**

- ▶ Use in all sectors: commercial - food production - transport - heavy industrial
- ▶ 2kW - 60kW machines capable of producing 60g - 800g of dry steam per minute!
- ▶ Economical running costs & no chemicals required.
- ▶ Sustainable, water conserving technology.

**OSPREYDEEPCLEAN**  
www.ospredc.com

+44 (0) 1242 513 123

sales@ospredc.com

Unit 3, Cheltenham Trade Park  
Gloucestershire, GL51 8LZ



# RMIG: We make ideas come to life

As the largest perforating company in the world, RMIG has over a century's experience in the perforation industry. This impressive size and experience means RMIG has a local presence in a range of markets, providing accessible contacts for customers no matter what their query.

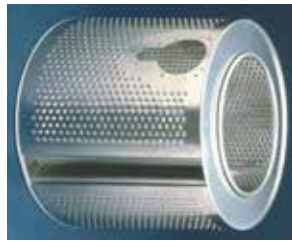

and are well suited for use in sterile environments. RMIG's perforated products also have numerous uses in the petrochemical sector, from industry specific applications such as filtration, to oil and gas exploration, as well as more general applications such as walkways in processing plants.



RMIG is dedicated to being an innovative and reliable solution provider in the perforation industry, as well as being recognised as a benchmark for customer service and optimised logistics.

RMIG's perforated sheets can be used effectively within a number of areas, and RMIG has six dedicated market sectors covering Industrial Processing, Food Processing, Buildings and Interiors, Multimedia and Communication, Automotive, and Household Appliances.



One particular area of Industrial Processing is medical and pharmaceutical, where RMIG's perforated materials are able to give firm tolerances during their manufacture,

Additionally, RMIG works with biomass drying applications. The demand for alternative sources of sustainable and renewable energy is always growing. RMIG's Bridge Slot sheets are the most effective way of drying woodchip to an optimum moisture content, ensuring boilers operate efficiently to benefit farming and agriculture.

floors in outdoor buildings. The bridge slot opening size determines the products that can be dried, which range from fine oilseed rape through to larger grains and cereals, as well as logs and wood chip drying.

The RMIG Bridge Slot sheets play an essential role when it comes to the design and manufacture of biomass drying floors. The combination of sheet thickness and opening size allows RMIG's sheets to be used either as a suspended floor in wood chip drying containers and trailers, or as drive-on drying

In the production of perforated dishwasher filters, RMIG offers the complete service from perforating and forming, including surface treatment, right up to final assembly complete with plastic rings and funnels. RMIG also has decades of experience in the manufacture of perforated sieves using highly developed technical methods and strict quality control systems to guarantee customers are receiving the best possible product.

**Contact**  
T +44 (0)1925 839610  
info.uk@rmig.com  
www.rmig.com/en

## Control Station

*Making Optimisation Easy!*

Control Station leads the process analytics field, offering monitoring, diagnostics, and optimisation solutions to global manufacturers. Our goal is simple: empower manufacturing excellence by improving production efficiency and throughput, and control loop performance across industries.



the Engineer's Choice Award as the market's best PID Controller Tuning Software and it is a two-time winner of Chemical Processing Magazine's Vaaler Award.

Manufacturers rely on automation for competitiveness, and Control Station's solutions are essential to that success.

Training & Skills Development: Practical Process Control workshops equip professionals to diagnose and fix control-related issues, licensed by 200+ global colleges and universities and certified by leading process manufacturers.

Our Lifecycle Solutions: PlantESP™ monitors plant-wide control systems, detecting production issues, performing root-cause analysis, and recommending corrective actions, resulting in optimised production systems, reducing downtime, and enhancing efficiency.

Our global customers are based in all industry segments including: Pharmaceuticals & Biotech, Manufacturing, Mining, Chemicals, Food & Beverage, and Oil & Gas.

LOOP-PRO™ is our leading software for process modelling and PID controller tuning, excelling in noisy and dynamic data applications, making it a valuable asset for industries with complex processes. It has been recognised numerous times for

Control Station is dedicated to helping manufacturers worldwide optimise production.

T 00353 (0)505 39900  
emeasales@controlstation.com  
www.controlstation.com

## Safety our priority



MacClancy and Sons Ltd, are a family run business, providing your industry with the best Explosion Protection equipment for the best price.

Spark® equipment. Everything we supply is fully EN, ATEX & NFPA certified for all types of combustible dust up to 250Kst.

We offer high-quality Explosion Protection and Spark Protection equipment from our wide range of Vent Panels, Flameless Vents and Isolation Valves as well as Sensors, Environmental and Safety Protection and our NEW Raptor Spark detection kits.

Rest assured that our manufacturing partners lead the way in safety protection, improving certification testing to reflect real world conditions and improve the latest standards.

The products we provide are competitively priced thanks to our exclusive contract to supply the UK with VigilEx® Safety Protection and Raptor

**For detailed information on VigilEx® and Raptor Spark® equipment and accessories, or for a quote, please email: info@macclancyandsons.co.uk**  
<http://www.vigilexuk.com>



Geo Green **Power**  
for a **Green** future

# TAKE CONTROL OF YOUR ENERGY

- ✔ Solar power
- ✔ Energy storage
- ✔ EV charging
- ✔ Service & Maintenance



**0800 988 3188**

[www.geogreenpower.com](http://www.geogreenpower.com)



# Anua Clean Air: Air pollution control specialist

Anua Clean Air UK Ltd are a specialist Air Pollution Control company with expertise in the field of biological treatment of air and Biogas. Anua are established leaders in the fields of high performance, low-cost emission abatement primarily based on our Patented Biofiltration and Bio scrubbing technologies.

Our Monashell™ and CrumRubber™ use recovered materials as the critical filtration component. The unique properties of these materials enhance capture and treatment which in turn provides multiple environmental benefits in terms



of Circular Economy, Carbon Footprint (low water and energy requirement and no consumables) and removal of harmful atmospheric pollutants.

During the past number of years along with its parent Company Anua Clean Air International limited and Italian Sister company Air Clean SRL we have been very active in the UK, Ireland and in overseas markets including Italy, France, the Middle East, China and the US. International Reference projects include Dual Pass Monashell Installations in Riyadh, Jeddah, Laguna Lake in the Philippine's, Coimbatore in India, and Sindos in Greece. For our new CrumRubber technology, we have supplied new installations in the Canary Islands, China, Oman and UK and Ireland. We are also currently working with Air Clean USA on the delivery of a number of new installations for the US market.

Anua Clean Air International also specialise in Equipment Health Checks and process optimisation and media replacement services. We have continued to perform System Health Checks and media replacement services on the many hundreds of Worldwide Monashell Installations.

[www.anuacleanair.co.uk](http://www.anuacleanair.co.uk)

## Need a disc filter?

Helapet offer customers unrivalled flexibility and quality in developing and producing replaceable disc filters.

A variety of in-line filter combinations are available offering a choice of housing, media, micron size and connectors for efficient filtration and clarification of air/gases and liquids.

- ✓ 100's of filter combinations
- ✓ Fast turnaround times - both for samples and production
- ✓ Individually designed to your specification
- ✓ Traceability by lot
- ✓ Low volumes at competitive prices - 100's, 1000's, 10,000's
- ✓ Comprehensive testing
- ✓ Bespoke printing for OEM and instrumentation applications

T: (01582) 501980 E: [sales@helapet.co.uk](mailto:sales@helapet.co.uk)  
W: [helapet.co.uk/inline-disc-filters](http://helapet.co.uk/inline-disc-filters)



"We chose Helapet filters as they offered the product, price and quantity we required, with the added bonus that the filters we have are branded with our details. In a competitive market this gives us an important edge"

Instrument Manufacturer, UK

**Helapet**  
A DriMed® Group Company



**GOLD & WASSALL**  
QUALITY HINGES FOR OVER 200 YEARS

# MAKING HINGES SINCE 1790

## 100% UK MANUFACTURED

Gold & Wassall are the UK's No.1 manufacturer of hinges. We provide a fully comprehensive manufacturing service, which enables us to offer any hinge, for any application.

All our hinges are manufactured at our premises in Tamworth, UK.

We have a huge stock range, all of which are available for immediate dispatch.

As well as our huge stock range, Gold & Wassall also offer a number of bespoke solutions which can be tailored to any application. Our ability to produce bespoke hinges is a cornerstone of our operation, we have manufactured over 250,000 unique hinges and counting. From the smallest delicate designs to the largest complex components, we have tackled endless challenging projects.

**Continuous Hinges**

**Butt/Backflap Hinges**

**Lift-Off Hinges**

**Heavy Duty Hinges**

**Special Purpose Hinges**



Please check our new website:  
**[www.goldwassallhinges.co.uk](http://www.goldwassallhinges.co.uk)**

Email [sales@goldwassallhinges.co.uk](mailto:sales@goldwassallhinges.co.uk) | Telephone **01827 63391**



# Bona: Enhancing the beauty of floors since 1919

## Bona®

Welcome to Bona – your go-to expert in floor care. Possessing over a century's worth of knowledge and innovation, we proudly stand at the forefront of the hardwood flooring sector, enhancing the beauty of floors since 1919. Our dedication to sustainable practices, groundbreaking solutions, and unparalleled excellence has solidified our reputation amongst both homeowners and professionals worldwide. With a comprehensive global footprint, Bona offers an extensive range of products and systems for the installation, restoration, and maintenance of flooring. Our commitment is to provide solutions that maintain the beauty and functionality of floors, throughout their lifetime.

For over a century, Bona has been a household name in floor care, and we are eager to continue on this path to a brighter future. Driven by our passion for flooring and a commitment to high standards, we aim to supply only the finest solutions for preserving and augmenting the beauty and resilience of various floor types.

Since its establishment in 1919 by Wilhelm Edner – a small grocery store owner in Malmö, Sweden where he discovered his affinity for coffee and sold bonvax, a product that polished and protected wood floors – Bona has been at the pinnacle of the hardwood floor industry. Today, backed by more than a century of innovation and expertise, Bona is a leading figure in floor care, committed to showcasing the natural beauty of your floors. Our Swedish heritage and history have sculpted our company's identity, fueling our drive towards sustainable business practices and ensuring that every facet of our operations considers the impact on our planet's precious resources. Our trailblazing spirit has led to significant



industry advancements, notably our early move to eliminate toxic chemicals from our finishes and our pioneering of dust containment systems to protect the air quality during floor sanding processes. Bona's high-quality products meet rigorous standards set by national and international environmental bodies.



Being the provider of choice for the world's most trafficked and prestigious buildings, Bona's solutions cater to floors that endure significant daily stress, ensuring sustainability and performance meet the highest standards. By offering the industry's most durable finishes and a complete system of eco-friendly products for floor care and maintenance, alongside a unique global network of Bona Certified Craftsmen, we enable our customers to achieve optimal results for their floors, earning the recommendation of professionals since 1919.

As we move forward into the next century, our values as a family-owned company remain unchanged; we are wholly focused on innovation, not only in hardwood but in all superior flooring materials including stone,



tile, laminate, resilient, and parquet. Our team is dedicated to identifying trends and delivering the best possible flooring solutions. Opting for Bona means choosing safe state-of-the-art products that achieve exceptional outcomes while enhancing the beauty of your flooring.

Reflecting on our rich heritage and accomplishments, we pay tribute to the heart of Bona – our team. With over 600 staff members and a presence in around 90 countries through direct subsidiaries and distributors, our success is built on the tireless effort, dedication, and commitment of our personnel to embody and uphold our company's core values every day. Their unwavering passion, commitment to excellence, and curiosity for innovation continue to drive our success.

Our commitment to sustainability and innovation has consistently been

recognised, earning Bona numerous accolades and certifications for our environmentally-friendly practices and superior-quality products, including the Nordic Swan Ecolabel, Greenguard Gold Certification, and the European Business Award for the Environment.

#### Facts and Figures

Bona employs over 600 people worldwide, operates five manufacturing facilities globally, and has a presence in 90 countries through 17 international subsidiaries and distributors. The company is headquartered in Malmö, Sweden, with additional subsidiaries in various countries including Austria, Belgium, Brazil, China, Czech Republic/Hungary/Slovakia, France, Germany, Poland, Romania, Singapore, Spain/Portugal, The Netherlands, the United Kingdom, and the US.

<https://www.bona.com/en-gb>





WITH US, ORGANISED BECOMES  
EVEN MORE ORGANISED



[www.bitto.com](http://www.bitto.com)



BITO Pallet live

Improve your pallet storage capacity and organisation with gravity fed roller decks.





OAKWAY

## Twice as safe

Warehouse and rack protection that prevents accidents and damage to people, racking, property and machinery.

- PROTECTION THAT RETURNS TO ITS ORIGINAL SHAPE AFTER IMPACT
- SHOCK ABSORPTION THAT LIMITS DAMAGE TO TRUCKS AND FLOORING
- STREAMLINED DESIGN THAT FREES UP WAREHOUSE FLOOR SPACE
- SAVE ON MAINTENANCE COSTS AND OPERATIONAL DOWNTIME



[www.oakwaystorage.co.uk](http://www.oakwaystorage.co.uk)

## Oakway Storage introduces a new flexible warehouse protection solution to the UK

Oakway Storage, a leading provider of warehouse design solutions, is proud to announce the launch of its latest product: flexible warehouse protection.

This innovative solution prevents accidents and damage to people, racks, property and machinery. Above and beyond traditional steel-fabricated protection, the Oakway Storage solution returns to its original shape after impact, reducing shock and damage, whilst also increasing floor space through a cleverly designed minimal footprint.

According to the Health and Safety Executive (HSE), over 5,000 reported accidents involve workplace transport every year in the UK. This alarming statistic underscores the importance of implementing safety measures to prevent workplace accidents and injuries.

The new product features a flexible design that absorbs the impact of a forklift or other heavy equipment without causing damage to vehicles, floors or the



protection itself. This popular feature offers cost-effective protection over a longer period than traditional steel protection.

Oakway Storage offers a full range of warehouse fit-out solutions, including pallet racking, mezzanine floors, shelving systems and complete turnkey project management, with a reputation for delivering full warehouse fit-outs, fast.

**For more information about Oakway Storage, including the flexible warehouse solutions, please visit the company's website at: <https://oakwaystorage.co.uk> or call: 01604 792255.**

# ecobat

## BATTERY

### Your Industrial Battery Specialists

- Batteries, Chargers & Accessories
- Maintenance and Repair
- Training
- Health & Safety Advice
- Inspections & Reports
- Replacement Programs
- Bespoke Chargers

Please send us an email if you would like to receive a copy of our new Industrial catalogue.



Stour House, Freebournes Road, Witham, Essex  
CM8 3UN

T: 01376 550825 | E: [serviceuk@ecobat.com](mailto:serviceuk@ecobat.com)

VISIT US AT [ECOBATBATTERY.COM](http://ECOBATBATTERY.COM)





## **MACHINESAFE** COMPLIANCE SOFTWARE

### MachineSafe, The Safety And Compliance **Software Platform.**

Discover how MachineSafe can streamline your machinery safety and compliance process.

- Intuitive app ideal for carrying out 'at machinery' inspections.
- Web version for asset and inspection management.
- Various inspection modules available including:
  - PUWER.
  - Risk Assessments.
  - New Machinery Audit.
  - EN 60204, EN 4413 & EN 4414.
  - MachineSafe Audit.
- Users can add their own inspection templates.
- Scalable platform depending on number of assets.
- Add additional company users.
- Integrated inspection Risk Assessments.
- Professional Reports.
- Training and support available.

**Contact MachineSafe to arrange your free Demonstration.**

[www.machinesafe.co.uk](http://www.machinesafe.co.uk)

[info@machinesafe.co.uk](mailto:info@machinesafe.co.uk)

01793 547018



# Streamlining safety and compliance inspections for machinery OEM's, end-users and safety consultants

## UK machinery safety

Machinery safety is a top priority across all industries to safeguard safe working practices. Despite best safety practices, HSE reported that tragically 135 workers were fatally injured at work during 2022/2023 (RIDDOR), with construction, agriculture/forestry/fishing and manufacturing reporting the highest fatalities. Machine hazards in manufacturing can range from machine guarding, electrical hazards, poor maintenance, mechanical hazards, to equipment malfunctions, and many more, with the onus placed on companies to become more stringent with the health & safety and regular inspections of machinery operations.

## The dreaded internal safety inspections

Automated assembly lines have now become standard practice across many warehouse and distribution, manufacturing and food & beverage companies, freeing up staff to carry out other important tasks. Needless to say, one area that hasn't changed much is the dreaded 'inspection clipboard,' with lots of tick boxes. It can often be a cumbersome job but putting it off can cause machinery failure, leading to costly downtime and in worst case scenarios, injuries or fatalities.

But what if there was another option?

## Introducing MachineSafe safety and compliance software

The MachineSafe safety and compliance software platform has been designed to fit a gap in the market for the inspection process by machinery safety engineers. With a rich background in conducting PUWER inspections, UKCA Marking, CE Marking and Machinery Risk Assessments, the MachineSafe engineers used this expertise to develop the platform. Managing Director, Jon Rowen is a member of the BSI Safeguarding of Machinery Committee and is well versed in the mechanics of machine safety protocols.



## Benefits of MachineSafe

We spoke to Jon to get a further insight into the benefits of MachineSafe for end users, "Our web and tablet-based platform affords optimised safety and compliance inspections of machinery and equipment across industries such as warehouse and distribution, manufacturing and food and beverage. The platform takes away the burden of inspections, which is a pain point for many companies across the UK. It is perfect for OEMs, machinery end-users and consultants who need timely machinery inspections and audits for stakeholders or customers, even for auditing new machinery at the manufacturers before it is shipped to your company."

"With inspection modules such as: Prevision and Use of Work Equipment Regulations Assessment (PUWER), Risk Assessments, New Machinery Audits, MachineSafe Audit, CE/UKCA Marking, electrical, pneumatic and hydraulic systems. Users can also add their own inspections to the MachineSafe platform for their own use."

## User-friendly and streamlined

The MachineSafe app can be easily downloaded from Google Play but for companies who would like more information, there are Zoom demonstrations, followed by in-person ones if required.

Following assessments and inspections, the data can be switched to a Cloud Platform and pdf reports can be printed, for ease and convenience.

That's not all.

MachineSafe offers training for upskilling teams on PUWER inspections, risk assessments and compliance support, as required.



"PUWER (Provision and Use of Work Equipment Regulations) places duties upon individuals and companies who own, operate or control work equipment. PUWER also places responsibilities on businesses and organisations whose employees



use work equipment, whether owned by them or not. The purpose of a PUWER inspection is to identify whether the equipment can be operated, adjusted and maintained safely and that any deterioration (for example, any defect, damage or wear) can be detected and remedied before it results in unacceptable risks."

"The MachineSafe PUWER module is available as a stand-alone module or is included in our Enterprise subscription is the ideal tool to manage and document your PUWER inspections."

"All MachineSafe subscriptions include all the core inspection modules, with templates available at the touch of a button. End-users can simply choose the subscription package that suits their requirements. The platform latest release now includes UI enhancements, Improved inspection templates and CE/UKCA marking plugin and our engineers are constantly looking at how to improve the platform going forward." concluded Jon.

## The age of technology

Industry 4.0 pushed advancements in automation, robotics, smart systems, AI, machine learning, big data analytics and IoT across many industries. The advent of Industry 5.0 however, is all about placing worker wellbeing at the epicentre of production processes and using new technologies to provide prosperity beyond jobs and growth while respecting the production limits of the planet. For many industries, this could translate to technology 'freeing' up staff to carry out other important tasks and MachineSafe is at the forefront of streamlined inspections, placing workers at the heart of safety.

For more information or to request a demo today, please see the details below:  
**T +44 (0)1793 547018**  
**info@machinesafe.co.uk**  
<https://machinesafe.co.uk>



### Surface Technology

**CURTISS - WRIGHT**



01635 279621 | www.cwst.co.uk

### Pollution Control Systems

**ERG**  
Air Pollution Control

- Flue gas scrubbing
- Desulphurisation
- Thermal oxidation
- VOC abatement
- Refurbishment projects and upgrades

Supplier of industrial air pollution control systems to the international process industry.

01403 290000 info@ergapc.co.uk  
www.ergapc.co.uk

### Electric Vehicles

**BRADSHAW**  
ELECTRIC VEHICLES



TOW TRACTORS  
LOAD CARRIERS  
BESPOKE BUILDS  
ROAD VEHICLES  
UTILITY VEHICLES  
PASSENGER VEHICLES

WWW.BRADSHAWEV.COM

### Hinges

**GOLD & WASSALL**  
EST. 1790



Quality hinges for over 200 years

01827 63391  
sales@goldwassalhinges.co.uk

### Springs & Pressings

**EUROPEAN**  
SPRINGS & PRESSINGS

Complete service support from design to manufacture

We offer full design and production of standard and bespoke metal components in a comprehensive range of materials. Our products range from tension, extension, compression, torsion and gas springs, to wire forms and metal pressings.

LESJOFORS  
a company of  
ARNO & COLSON

MADE IN BRITAIN

For all enquiries please call us on: +44 20 8655 1200 or email us at: sales@european springs.com

### Lighting

**CML**  
INNOVATIVE TECHNOLOGIES  
WHERE INNOVATION COMES TO LIGHT



CML Innovative Technologies Ltd.  
69/70 Eastern Way, Bury St Edmunds,  
Suffolk, IP32 7AB, United Kingdom  
Tel: +44 (0) 1284 714700 email: uksales@cml-it.com  
www.cml-it.com

### Force Measurement

**interface**  
FORCE MEASUREMENT SOLUTIONS



Load Cell, Torque and Pressure Sensor Specialist

www.interfaceforce.co.uk

### Humidity Control

**HUMIDITY SOLUTIONS**  
Independently better



HUMIDITY CONTROL MADE EASY

01372 571200  
www.humiditysolutions.co.uk

### Logistics

EXCELLENCE IN  
Global logistics



noatum logistics

### Valves

**We Are Valves.**

**oliver valves**

Instrumentation & DBB Valves

- Severe Service 650°C, 10K psi
- Manifolds, Needle, Check, DBB Valves to 22.5K psi
- Cryogenic
- Forged & Bolted Construction

We Manufacture Valves for Global Energy Projects. Find Your Local Supplier - Contact Us Today.

+44 (0)1565 632 636  
sales@valves.co.uk | www.valves.co.uk

### Water Technology

QUALITY PRODUCTS & SERVICES

**euroby**

- SALES • RENTAL • MAINTENANCE •
- REFURBISHMENT • SPARE PARTS •

SUPPLIERS OF LIQUID AND SOLID SEPARATION TECHNOLOGIES TO THE WATER AND INDUSTRIAL MARKETS

Euroby Ltd  
New Dawn House, Gorse Lane,  
High Salvington, Werthing, Sussex BN13 3BX  
T - 01903 69 44 00 www.euroby.com  
F - 01903 69 44 77 E - sales@euroby.com

### Glue Gun Services

**Proflex**  
Shaped Hot Melt

**Packaging Glue Sticks & Glue Guns**



Passfield Business Centre, Lynchborough Road  
Passfield, Hampshire GU30 7SB  
Telephone: 01428 751 755 Email: enquiries@adco.co.uk  
www.adco.co.uk



**DMN**  
WESTINGHOUSE

# WE ADD RELIABILITY TO DRY BULK HANDLING INDUSTRIES

## TAILORED SOLUTIONS AND SOLID SUPPORT FOR VARIOUS INDUSTRIES WORLDWIDE

Whatever industry you are in, from plastics to pharmaceuticals and from dairy to aquaculture, you wouldn't want your production compromised by faltering input of raw materials.

Let DMN-WESTINGHOUSE add reliability to your dry bulk handling processes. Since 1950, we have excelled in designing and manufacturing high-end rotary valves and diverter valves with a stark focus on durability, cleanability and compliance.

Discover your future-proof solution at [dmnwestinghouse.com](http://dmnwestinghouse.com)



USDA



[DMNWESTINGHOUSE.COM](http://DMNWESTINGHOUSE.COM)

FUTURE-PROOF VALUE SINCE 1950

# Goupil Range

*An ideal alternative to combat ongoing charging shortage.*

The EV LGV fleet market is growing, with volumes tipped to expand from 5.9% of the market last year to 9.4% across 2024.

However, issues such as a lack of sufficient charging stations across the country is impeding growth, says the SMMT.

Without further investment being made into charging infrastructure, there is a concern this could incite a lack of confidence due to limited access, and therefore restrict sales.

In the case of utility vehicles, which traditionally operate in urban centres or on large-scale sites, the ongoing charging conundrum offers a frustrating dilemma for organisations in the public and private sectors.

A range of vehicles which has become increasingly popular across these sectors in recent years that remove the irritation of sourcing available charge points or investing into expensive charging stations, are the all-electric Goupil light commercial vehicle models.

The Goupils, which are supplied exclusively in the UK by leading electric utility vehicle supplier and manufacturer Bradshaw Electric Vehicles, are equipped with a single-phase onboard charger and can be conveniently plugged into any standard 230-volt domestic socket, which eliminates the requirement for costly or specialised charging infrastructure.

Bradshaw Electric Vehicles has witnessed an increasing transformation and shifting attitudes towards electric vehicles over the past four decades, with the rising popularity of its all-electric Goupil range within the private and public sector being a personal testament to this accelerating paradigm shift.

Specifically designed and categorised as low-speed electric vehicles (LSV), the Goupils are homologated for road use making them ideal for start stop and



last mile applications, while also being particularly suitable for sites connected by public highways.

With an increasing emphasis on sustainability in towns and cities across the UK, they also offer a safer and more versatile option to access car-free zones, cities, and areas with low emissions. Alongside this, as urban areas become increasingly pedestrianised, the Goupils' compact size and generous payloads mean that they are able to operate seamlessly in areas where LGVs cannot.

While a key barrier to entry into the EV market for a number of operators is a lack of available charging infrastructure, Ramsy Labassi at Bradshaw Electric Vehicles has suggested that the Goupil range can still provide businesses and local authorities with a viable option to make the switch without the concern of sourcing or investing into charging stations.

Ramsy commented: "Addressing this infrastructure gap is of course paramount in empowering fleet operators to embrace electric vehicles and unlock the full potential of a cleaner, greener future. However, a lack of available charging stations shouldn't mean that operators must grapple with

the uncertainty of where and when they can recharge their fleets if they choose to adopt electric options over their petrol or diesel counterparts.

"In suitable environments, the versatile Goupil light commercial vehicle range, which come with a number of configurations, acts as an ideal, alternative solution to meet the diverse needs of industrial and commercial operations across a wide range of capacities – and most importantly they don't require charging infrastructure in place to be powered as they can be charged in the same manner as any electrical device.

"Since their introduction into the UK, the Goupil range has become a vital component of an operator's commercial fleet in recent years, enabling them to conduct tasks such as grounds maintenance, waste and litter collections, deliveries, street cleaning, final mile delivery, as well as several other unique applications – and their flexible and convenient charging capabilities has played a significant role in this, which is why they continue to be a vehicle of choice across a wide range of sectors."

**Contact**  
**T +33 5 53 79 39 39**  
[www.goupil-ev.com/en](http://www.goupil-ev.com/en)