

## Building & Construction Review



### Introducing the METROPOLIS grating

Ductile iron gratings on surface water drainage channels don't necessarily need to be utilitarian in appearance with geometric slots or meshes.

Inspired by the patterns made by water flowing down a stream, the surface design of the Hauraton METROPOLIS grating is reminiscent of the ART NOUVEAU style and later ART DECO period. Planners and landscape architects can now choose this grating to add

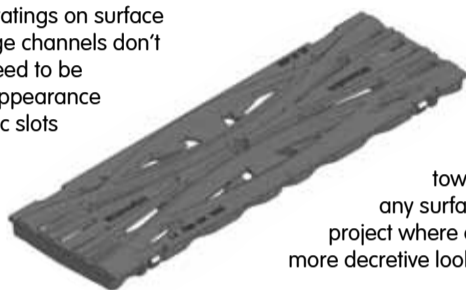

a touch of class to their schemes in historic and pre-modern townscapes or any surface drainage project where an aesthetic, more decorative look is desired.

The METROPOLIS grating is sold separately to fit FASERFIX® KS channels or factory fitted to RECYFIX® PRO channels. Gratings are available in nominal widths of 100mm and 200mm. Sizing details for FASERFIX® KS 100 and FASERFIX® KS 200, with METROPOLIS gratings can be found in the Hauraton CIVILS catalogue. Sizing details for RECYFIX® PRO 100 and RECYFIX® PRO 200, with METROPOLIS gratings can be found in the Hauraton LANDSCAPE catalogue. The channels provide a loading capacity up to Class D400. All METROPOLIS grating are finished in anti-corrosion, Black KTL finish.

T +44 (0)1582 501380  
[sales@hauraton.co.uk](mailto:sales@hauraton.co.uk)  
[www.hauraton.co.uk](http://www.hauraton.co.uk)  
[www.drainage-projects.co.uk](http://www.drainage-projects.co.uk)



### Pure Decadence from Old London

We have recently updated our stunning traditional bathroom range, Old London, with the addition of a beautiful new collection of classic bathroom furniture featuring magnificent polished marble vanity basins for grand bathroom looks the perfect choice for period-style bathrooms, en-suites and cloakrooms.

Overflowing with decadence and sophistication, the new floor-standing range of cabinets and coordinating accessories follows the signature Old London look centred on luxurious classic design fused with the latest innovations in bathroom technology.

The striking new pieces of bathroom furniture feature framed shaker-style door fronts, tongue and groove styling to side panels, elegant curves to decorative plinths and brushed chrome knobs. The collection is also available in three heritage colours; Twilight Blue, Storm Grey and Timeless Sand, with a textured woodgrain finish. The units include soft-close doors as well as being supplied ready assembled for quality and ease of installation.

To add a touch of opulence, the choice of vanity units come with a polished marble top, in white, black or grey marble, or alternatively, in crisp white ceramic. The comprehensive selection of vanity units with basins includes both standard sized vanity units (600mm and 800mm wide), as well as the popular twin, 'his and hers' unit measuring in at 1,200mm. There is also a cloakroom range available in 515mm, 560mm and 600mm widths, including



a practical corner cabinet at 595mm x 449mm.

For further flexible and design-led storage solutions, the new Old London Furniture range also includes a matching mirror cabinet, mirror, tall boy unit, WC unit, bath panels and seat – all flawlessly finished for a timeless, yet stunning bathroom look.

Like all bathroom furniture from Hudson Reed, the new Old London collection is manufactured to exacting quality standards, is extremely hard-wearing and comes with a five-year guarantee for extra peace of mind.

To find your nearest Old London stockist, visit the Hudson Reed website: [www.hudsonreed.co.uk/how-to-order](http://www.hudsonreed.co.uk/how-to-order) or contact: +44 (0)1422 41710.



Direct Hoist  
See on page

3



Cabletrail  
See on page

5



AJ Products  
See on page

7

**DUDLEY INDUSTRIES**  
SHEET METAL EXPERTISE SINCE 1942

**For the ultimate in Washroom Style**  
Stylish dispensers designed and manufactured to the highest quality standard for all public washrooms.

**Modulo - Behind the Mirror Range**

**Platinum Range**

**Recessed Range**

Sales: +44 (0)1253 738 311  
 E-mail: [sales@dudleyindustries.com](mailto:sales@dudleyindustries.com)  
[www.dudleyindustries.com](http://www.dudleyindustries.com)

**WASHROOM ACCESSORIES**

### Washroom accessories

Dudley Industries' Platinum washroom dispenser range promises to enhance any commercial washroom. Made to the highest standard from quality stainless steel the Platinum range is one of the most comprehensive washroom ranges available. Finished with an innovative lacquer that helps to prevent unsightly fingerprint marks it ensures that the dispensers stay looking clean and hygienic whilst being easy to clean.

Stainless steel provides a robust construction suitable for the busiest of washrooms whilst delivering sleek lines to complement the most stylish of decors. The Platinum range provides all the essentials including air freshener, toilet roll holders, soap dispensers, paper towel dispensers and waste bins but also includes shower gel dispensers, toilet seat cleaners, roller towel cabinet and hand dryer ensuring there is the perfect mix of hygiene dispensers for all locations.

Designed and made in Lancashire by expert sheet metal engineers Dudley Industries who have been manufacturing quality metal washroom dispensers since 1942.

The Platinum collection is just one of the latest innovations from Dudley



Industries. The company have also recently introduced dispensers designed specifically for the care sector. The Anti-ligature range protects the most vulnerable through its considered design and attention to detail to help prevent ligatures being attached to cause self-harm. The Dementia range uses colour cues to help patients with Dementia.

A washroom can be a testing environment for those with Dementia but by installing easy to use, coloured dispensers the hand washing process becomes less challenging, helping to maintain the independence of users for as long as possible.

Contact  
 T +44 (0)1253 738311  
[sales@dudleyindustries.com](mailto:sales@dudleyindustries.com)  
[www.dudleyindustries.com](http://www.dudleyindustries.com)



GLW Engineering  
See on page

9



TCFM  
See on page

13



Premier Guarantee  
See on page

23



# Beautiful Wildflower Meadows for any environment

Building and Construction Review is pleased to announce that Pictorial Meadows has received our **Commitment to Excellence Award**, for their dedication to making stunning meadow planting compositions available to everyone.

Pictorial Meadows was born out of an initial project 20 years ago at the University of Sheffield, the world's leading centre for ecological planting design, to develop beautiful meadows which would thrive on average garden soils, unlike their native meadow counterparts which needed drastically altered soils to thrive. Through this project, they developed a drastically different approach to meadow landscapes, combining ecology with design. With experimental plots in Sheffield, the designs were improved and research was carried out into the care and establishment of meadows, allowing them to be used across various projects including large scale public schemes, major visitor attractions (they were integral to the success of the Olympic Park) and new housing developments.

Since 2004, Pictorial Meadows has been part owned by the University of Sheffield and social enterprise Green Estate. Now, the company is



made up of landscape architects, researchers, horticulturalists, and landscape managers, meaning Pictorial Meadows can offer great products as well as specialist skills.

"Our capabilities range from just providing the seeds and turf products all the way to an all-inclusive service," Jonathan Wild explains. "We can offer consultations, with a full report including recommendations on the best seed mixes and designs. Then, we can supply the seeds or offer a landscaping service. We can also provide a full maintenance service to make it easier for customers to achieve a meadow and keep it in good condition. As well as this, we offer bespoke mixes, meaning that customers can get involved in the design process and receive a customised meadow."

As well as unrivalled technical knowledge and design interests, Pictorial Meadows can control all aspects of product quality in-house. What's more, their designs are based on carefully composed recipes, which allow complex and well-structured meadows to be established and to be improved each year after the initial planting.



A particular product of interest is their PM Turf. "This is the easiest way for our customers to get a meadow. We grow the turf at our farm, and then take it to the customer, ready to be laid." The PM Turf is sent freshly harvested from the farm, which arrives on a pallet to be easily lifted off and laid by two people.

Pictorial Meadows delivers its products across the UK and increasingly in Europe, and they are working to continue their international expansion

and help transform environments worldwide. For more information, head to their website to check out their extensive list of case studies where they have transformed city centres, universities and private homes up and down the country. Alternatively, get in touch using the contact details below.



T +44 (0)1142 677635  
[info@pictorialmeadows.co.uk](mailto:info@pictorialmeadows.co.uk)  
[www.pictorialmeadows.co.uk](http://www.pictorialmeadows.co.uk)



## Pictorial Meadows

Superior quality designer meadows from seed and PMturf based on 20 years of research and development

Choose from a wide selection of annual and perennial meadow mixes

As seen in RHS and National Trust gardens across the UK, and Botanical Gardens across Europe.

**Request your catalogue now:**

01142 677 635

[PictorialMeadows.co.uk](http://PictorialMeadows.co.uk)

Meadow seed and turf supply

Design and consultation

Meadow installation

Training and CPDS



# The height of excellence

Excellence isn't about maximum profits. It's not about winning awards. For Direct Hoist, the commitment to excellence extends onto every level – just like the firm's wide range of hoists and lifting platforms.

Direct Hoist's commitment to excellence means keeping up with customer demands and accurately assessing not just what's needed now but what the site may also require many months down the line.

Company founder Rob Wilson has been in the construction hoist industry for over 30 years, and uses his vast experience to preempt clients' requirements.

Rob says, "We offer free advice, site surveys and expert project planning. We establish what's essential, and what may be wanted in three or six months' time. Customers' needs often change, and it's more cost-effective for us to provide the right equipment from day one.

"We know what, where, when and how big, and we advise accordingly. Our know-how ensures we get it right every time."

Thanks to Direct Hoist's fleet of over 40 hoists, there's a tool for every task. From scaffold hoists to gantry hoists, from tile hoists to 5x2.9m lifting platforms, Direct Hoist has modern, highly-maintained hoists always available for hire.

Direct Hoist also offers sales and servicing, specialising in market-leading GEDA equipment. "It's the best machinery available from the best manufacturer," comments Rob. "GEDA is a traditional German brand that's been an industry leader for 90 years. It's the finest on the market for quality and reliability."



Modern construction techniques are calling for bigger and ever more specialised products, and health-and-safety regulations mean you need good reason not to have a hoist on site; the days of clambering up and down ladders are long gone. Hoist manufacturers are working hard to keep up with demand, allowing items such as entire prefabricated bathroom pods to be lifted into position.

"It's all about the speed of build, and the most effective solutions to reduce costs," says Rob.

He continues, "Construction hoists are part of a fast-moving industry, and we're one of the best in the game. These days I spend my time running the company rather than at the pointy end, so I can ensure Direct Hoist is at the forefront. We're investing in our website – customers can see what's new, get quotes and buy online – and we're committed to staff training and development."

**"We offer free advice, site surveys and expert project planning"**

Direct Hoist's fully-skilled workforce includes professional hoist technicians and qualified mechanical engineers. Rob realises it's critical for his team to be nurtured, and the firm even has its own fast-track scheme for NVQs.

Although Direct Hoist has the infrastructure of a big business, Rob ensures its ethics and client relationships retain a personal touch. He says, "We bend over backwards to help them; that's why they keep coming back. They trust us to dot the Is and cross all the Ts."

Excellence, for Direct Hoist, is about saving money instead of cutting costs; it's about insisting on first-rate products and services to provide only the best for customers.

Contact  
T +44 (0)1724 781647  
[www.directhoist.co.uk](http://www.directhoist.co.uk)

**"Construction hoists are part of a fast-moving industry, and we're one of the best in the game"**





# Aquaforno: Leading the revolution in outdoor cooking



Aquaforno is the brainchild of Tim and Karen Rhodes, a truly revolutionary outdoor cooking solution which is so much more. The idea for Aquaforno initially came about when Tim and Karen had to construct a contraption for an outdoor gathering. They faced the not-so-easy task of making a fire pit also capable of cooking pizzas. The contraption proved successful, and they began to wonder what more could be done with it and how the idea could be developed.

Well, after several years of research, planning and product development Tim and Karen are extremely proud to present a highly innovative product: the

Aquaforno. The ultimate outdoor cooking stove capable of a great many functions, enthusiasts of the outdoors truly need look no further than the Aquaforno. The stove serves as a fire pit or chiminea, a pizza oven, a grill, a smoker and has a water tank fitted allowing access to boiling water through an



integrated tap on the side of the stove. The design allows for a frying pan to be placed on top, so you can cook anything from pizzas to paellas to a full English breakfast with the utmost ease of use. Place a casserole dish in the top section and cook chilli con carne or bake an apple crumble. The possibilities are staggering. Oh, and the entire stove can be collapsed and placed into a padded backpack in only 10 minutes all thanks to the innovative telescopic design.

It's no wonder the Aquaforno has gained such considerable attention since its inception, being featured on Channel 5's The Gadget Show (and feeding the team!) and featured by The Hairy Bikers, who cooked scrumptious rye bread in the Aquaforno and took the multi-functional stove on some of their adventures.

T +44 (0)1189 304977  
karen@aquaforno.com  
www.aquaforno.com



Tel 01189 304977  
www.aquaforno.com

## Lighting News

### Let there be light



Here at LED Wholesale Exchange, we consider ourselves privileged to be able to make a valuable contribution to making this available and affordable to increasing numbers of people everywhere – available, because by using less electricity, there is more light to go around for everyone, and affordable because although the initial cost of the bulbs themselves is higher than that of the old technologies, the cost savings to the user are dramatic (usually 80%-85% of the equivalent incandescent measured by the Wattage

consumed). We are the exclusive distributors of the superb ALD brand with its cutting edge technology.

LED Wholesale Exchange are fully committed to promoting the adoption of LED lighting. The benefits for consumers, industry and the environment are clear to us. We can see the light – it's bright, clean and energy-efficient.

T +44 (0)20 3432 7117  
info@ledexchange.co.uk  
www.ledexchange.co.uk

### Edge lighting made easy

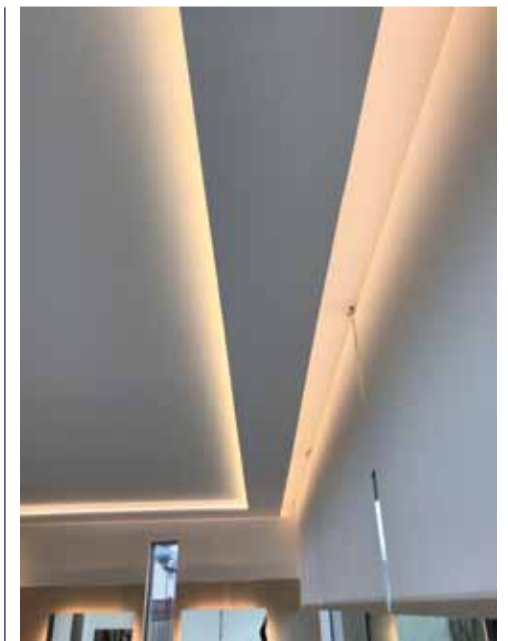

Enhancing an interior can be an expensive task but not utilising our unique LED edge lighting profiles. Designed to be cost-effective yet create stunning results. These profiles become the key component to a lighting concept.

Options being for a flat ceiling or a corner detail the aluminium trims form a sharp edge perfect for plastering to. The aluminium also acts as the perfect heat sink for LED keeping the running temperature low.

For the LED strip, simply select the colour temperature and output, whether it is single colour, dim to warm or colour changing the options are many. After selecting the LED, select the driver, either switched, triac, DALI, 1-10V, DMX, 12V or 24V, the choice is yours. Typical applications are washing light round

cornices, coffering, roof light wells, light panelling, beam edges, skirtings and wall recesses. When switched off the edge trim blends into the interior almost unnoticeable.

When on, the room is washed with soft reflected light, the perfect way to illuminate a room and to avoid the error of too many down lights.

Available in 3m lengths for ease of transportation and installation, these trims will transform the way you see light being used to enhance a room giving it added value and exclusivity.

T +44 (0)7725 560653  
david@ald-edge.com  
www.ald-edge.com





# Organic, manageable growth is key to success for Demolition and Construction Site Service Specialists



Building and Construction Review is **recommending** Thompsons of Prudhoe for their on-going commitment to the construction industry.

Thompsons of Prudhoe was established by Margaret and William Thompson in 1948. Offering the construction industry a wealth of knowledge throughout 70 years of experience, Thompsons of Prudhoe bolsters a prestigious repute of being a 'one-stop-shop' for delivering services within demolition and dismantling, asbestos removal, site clearance and reclamation, earthworks, concrete, quarries, aggregates and agricultural lime.

With their head office situated in Northumberland, the company also maintains a variety of facilities within Durham, Gateshead, Bradford, Cumbria, Edinburgh and Aberdeen.

Incorporating their work force expertise with their technological advancements in equipment, they produce the perfect solution for demolition and construction site services. The company uses their own plant and equipment, enabling them to produce an all-encompassing service for their clients allowing them to deal with one company throughout the entire site preparation and enabling process, from initial consultation to handover of the site ready for the construction phase.

Understanding their clients' needs is a big part of the process and is an area that Thompsons of Prudhoe excels in. Speaking to William Thompson Bid/Business Development Manager, on the way the company looks after their clients' best interests, he told us that, "Each of our sites contains its own supervisor who is



solely dedicated to that specific site, reassuring our customers that their sites receive a one-to-one experience with our team."

Seeing numerous company advances since their first years of production, Thompsons of Prudhoe maintains their original working ethos, with generations of Thompson family members working in the company throughout history. The company encompasses their family run approach to business and infuses their team with experienced industry professionals who are not family members, producing the most expansive knowledgeable management team possible.

"We cherish employee loyalty and invest within ourselves to further train and enhance our work force. We have found that this work ethos has been an extremely well received and in addition we find we have a very low turnover of staff."

With a strong emphasis on maintaining and nourishing all of their employees, Thompsons of Prudhoe values the individuals within their workforce and encourages development. In fact, the company invests extensively within their team and equipment, striving for the highest quality possible in production and in their services. With this in mind, the company has seen a healthy profit reached within latest years and therefore reinvested this within the company, leading to 200 ton excavators being purchased and now in use, as part of Thompsons of Prudhoe's continuous development plans. Speaking to William Thompson he also stated that, "Investing in ourselves is key; we find work to fit our team. We find that looking after the staff you have is the most effective way of producing the best team possible."

A great addition to the company's achievements this year saw their very own Grant Gibson being awarded the prestigious title of NFDC Demolition Supervisor of the Year. Presented at the National Federation of Demolition Contractors annual awards in London, the award was a welcome achievement for Grant Gibson. Speaking on this, William told us that, "Grant



has been working with us since 1991 and we are so pleased for him to win this award, it truly reflects the faith and investment that we put into our employees."

In terms of future plans for Thompsons of Prudhoe, William expanded that, "Organic growth is what we adhere to and we plan to develop this further through expansion and manageable growth."

T +44 (0)1661 832422  
www.thompsonsofprudhoe.com



**CABLE TRAIL CABLE MANAGEMENT INNOVATION**

- Super Strength Tri-hooks
- Fix by Cable Tie, Magnet, Bolt or Hanger
- Internal and External Cable Protectors. Available with 2, 3 or 5 Channels
- Indoor Cable Management
- Pedestrian 1 Piece Cable Protector
- Highly Durable Cable Mat

Tel: 01423 611610  
Email: enquires@cabletrail.com  
www.cabletrail.co.uk

## Cable management made easy

Within this issue of Building and Construction Review, we are recommending UK leading company Cable Trail for their outstanding work within the cable management industry.

Cable Trail deliver expert services for cable management and identification solutions, providing a wealth of knowledge utilised through their expert advice. Established in August 2015 by Nigel Myers, Cable Trail has been developing and expanding considerably since its inception.

Specialists in providing adaptable and tailored solutions for cable management and product identification needs of their client, Cable Trail provide two product lines. I spoke to founder Nigel Myers who had the following to say, "We don't just sell products, we offer and provide



solutions and we aspire to find a solution to fit every customer we have."

Another development for the company has also been their identification solutions. Included within this service, Cable Trail provides tags and identification products such as; Aluminium Tags, Cable Ties, Polyurethane Tags, RFID tags and Security Seals. Allowing customers to personalise the identification tags, Cable Trail's identification solutions provide customers with a manageable, visual and organised identification process.

Cable Trail delivers not only temporary cable solutions for building projects, but also permanent tailored solutions; something that Cable Trail provides effortlessly. With a wide portfolio of products and solutions, Cable Trail's

team of experts work tirelessly to sort and provide solutions for their customers.

After substantial growth achieved by the company, Cable Trail moved to larger premises, based in Wetherby in September 2018. Speaking to Nigel Myers on the success the company has achieved thus far and what plans they have moving forward, he told me that "Constant development has been a big part of what we do, being an engineer based company, we have found that our solutions are unique and we can work to tailor solutions for our customers through our own extensive knowledge. We plan to maintain constant development of products and are currently looking to produce a range of ATEX products for the oil and gas industry."

T +44 (0)1423 611610  
www.cabletrail.co.uk



# Your flat roofing systems specialist

Building & Construction Review is extremely happy to announce that Tuff Waterproofing have been deservedly chosen for this issue's **BCR Recommends profile**.

Tuff Waterproofing attended the Build Show where they showcased their range of roofing materials, equipment and services. Tuff Waterproofing specialise in manufacturing and supplying heavy-duty GRP waterproof flat roof systems, as well as assistive products. The company was first set up in 2011 and grew out of an installation company that already had 30 years of experience. Heading Tuff Waterproofing is a considerably experienced and knowledgeable team, all of whom have over decades of experience in the industry. Not only does this allow them to supply their unrivalled flat roof systems, but it also means that they can provide top notch training, support and technical advice too. Compared to those who specialise in solely manufacturing or installation, Tuff Waterproofing are able to supply a comprehensive service that works closely with customers and contractors.

We spoke to Gregory Gimenez, Managing Director at Tuff Waterproofing, who explained, "The life blood of Tuff Waterproofing is in our ability to provide exceptional training and professional support system for all of our clients. Our current dedicated team has between 15 and 20 years of experience in development and installation of our products thereby offering the very best in technical advice in the business."

Based in North Yorkshire, Tuff Waterproofing supply to Builders Merchants and Roofing Centres throughout the UK. In addition to being one of the UK's leading providers of waterproof flat roofing systems, they are also incredibly proud to work in collaboration with Velux with regard to their highly sought after flat roof windows. As one of a select few to be chosen by Velux, a globally recognised multi-national group, they were held in extremely high recognition by those at the Build Show.

As for Tuff Waterproofing's products, they have a wide and varied product range to choose from which were also on display at the trade event. One notable and popular product is the TuffStuff® Grey Slate Top Coat that comes ready mixed for faster application and comes in a 15kg tin that can cover an impressive 30 square meters. Other TuffStuff coats include Basecoat (15kg) and application tools. Tuff Waterproofing also supply catalysts, reinforcing mat, roof trims and much more. Visitors of the UK Construction Week were particularly impressed by their newly launched TuffStuff® 10m<sup>2</sup> Roof Pack, an extensive one stop solution kit containing everything needed for installing a 10m<sup>2</sup> flat roof (OSB 3 Board and Trims to be sourced separately).

It contains a base coat resin, grey slate top coat, catalyst, reinforcement mat, finishing tissue, a wide bandage, GRP trim adhesive, latex gloves and finally a warranty certificate and installation manual.

When it comes to their training and technical support, Tuff Waterproofing have a committed and robust support team that prides itself on helping customers achieve the most of their



products, resolving any problems and minimising future issues.

If you would like to find out more on Tuff Waterproofing or how they can help you can the roof you require, then don't hesitate to get into contact today.

T +44 (0)1977 680250  
[www.tuffstuff.co.uk](http://www.tuffstuff.co.uk)



T: 01977 680250

F: 01977 680284

E: [orders@tuffwaterproofing.co.uk](mailto:orders@tuffwaterproofing.co.uk)



**TuffStuff® is the UK's premium designer, manufacturer and supplier of heavy-duty GRP waterproof flat roofing systems.**

**From our bespoke premises in North Yorkshire we supply our products through a dedicated Stockist network located throughout the country.**

**TuffStuff® has a dedicated product development team that work closely with customers and our own UK based manufacturing facility to produce an evolving product range that is suitable for multiple flat roof applications.**

**Please visit [www.tuffstuff.co.uk](http://www.tuffstuff.co.uk)**





# One stop shop for smart, modern furniture

AJ Products was established in Sweden in 1975 by the current CEO and Owner Anders Johansson, and has been operating in the UK since 1999. The company is now represented in 19 European countries with 2 manufacturing plants and over 800 employees, and is still expanding every year with no signs of slowing down.

Currently in their 44th year of manufacturing excellence and unrivalled customer service, AJ Products is a leading supplier and manufacturer of over 15,000 products, including desking, seating, racking, shelving, lockers, goods moving equipment, bins, and trolleys. Indeed, AJ Products is the definition of a one stop shop for individuals, SMEs and global corporates across the world.

"One of our unique selling points is that every business and home could find something in our catalogue or website," explains David English, UK Managing Director. "Our customers can get everything they need for every part of their business directly from us. As well as this, we offer space planning and design consultation services, and we can offer free delivery with no minimum order."

Another significant advantage of AJ Products is their passion for health and wellbeing in the workplace, and they are striving to make Britain a happier and healthier place to work. They have a range of electric sit-stand desking, anti-fatigue mats, and active seating, which are stools that



make you sit upright and in the correct position. What's more, AJ Products now has a sit-stand conference table, which has been shortlisted for the European Office Product of the Year. Research has found that standing for meetings mean they become shorter, more productive and healthier. In fact, standing for three hours a day burns the same amount of calories as running 10 marathons a year.

There is no doubt that AJ Products can offer everything a customer could need, a testament to their short but sweet motto, 'Surprisingly More.' Indeed, this was born from when the company fitted out the Swedish Ice Hockey team's stadium, where they provided all their requirements for a complete fit out. This was not a one off success; AJ Projects repeatedly delivers an all-encompassing service that goes above and beyond what their customers expect. This is in addition to being known in Sweden as the 'happy company,' simply because



they are always trying to have fun in what they do, and are constantly ensuring the products they provide truly make a difference to their clients.

With numerous future plans to look out for, AJ Products is growing 30% year on year in the UK and Europe, building a strong foundation for investment and development. Recently, they invested £1 million in their metal factory in order to provide better products more quickly. As well as this, they have been exhibiting at multiple trade shows including the FM show at London's ExCel Centre, and London Build. They will be in attendance once again at the FM Show this year, 18-20 June, where visitors can see some of the company's product range and take advantage of exclusive offers. AJ Products is also planning

to attend more shows in 2020 in order to further raise brand awareness.

For more information, head to their website or use the contact details below.

**Contact**  
**T 0800 634 4369**  
**info@ajproducts.co.uk**  
**www.ajproducts.co.uk**



RCM Products offers a broad range of bespoke products, over 70 years of industry experience with customer service to match.

Enquire now 01234 843303 • sales@rcmproducts.co.uk  
[www.rcmproducts.co.uk](http://www.rcmproducts.co.uk)



# LeeSan celebrating 30th anniversary

Building and Construction Review are recommending LeeSan for their ongoing commitment to their customers in providing the best range of diverse sanitation solutions.

Based in Fenny Crompton, Warwickshire, LeeSan is currently celebrating a successful 30 years of business. When they were starting out, LeeSan provided sanitation solutions for the marine industry and are the single largest source of marine sanitation equipment. Members of British Marine, LeeSan has broadened their solutions and offer a well-versed selection of sanitation solutions adaptable across a diverse range of industries including marine, automotive, welfare, leisure

and many more. Some of the facilities that LeeSan provides sanitation solutions for include mobile vehicle, canal boats, horse boxes, cabins and other portable facilities.

Speaking to Karl Sutcliffe, Director for LeeSan, he told us that, "A lot of what we provide is a tailored solution to meet the needs of our customers. We work with a wide range of industry sectors and we like to work closely with our customers to make sure they receive the best sanitation solutions possible."

In terms of products and services, LeeSan focuses on finding the perfect solution for their customers' needs including bespoke tailoring



of solutions. Providing spare parts, accessories, pumping solutions and many more services, Karl expanded, "My main focus for the company has always been receiving customer satisfaction and helping our customers enhance their facilities, and we make sure they receive the most cost-effective, efficient sanitation solution for them."

Customer satisfaction is an important part of LeeSan's business, devoted to building strong lasting relationships with their customers. LeeSan is a sponsor of the Crick Boat Show's 20th Anniversary, taking place this May, a notable example of how LeeSan is going the extra mile in terms of looking after their community of customers who use and promote

them. "The Crick Boat show for us is not just about the great exposure it produces for us but it's also an important way for us to give back to a community that we provide services for."

Upon speaking to Karl about the importance of looking after their customers, he stated that, "It's a work ethic that I gained from father, working and creating personal relationships with customers is crucial. We look after our customers and they look after us in return by passing on our name and broadening our network, based on our reputation."

T +44 (0)1295 770000  
www.lesan.com

# Zoo Architectural Hardware



Zoo Hardware Ltd are designers and suppliers of architectural door hardware including door handles, knobs, locks, cylinders, door closers, hinges and more. All of their products are produced to the highest quality in aluminium, brass, steel and zinc. Every item they produce is selected for its quality and value for money and they never compromise quality for cheaper prices. Zoo Hardware are confident in their belief that they can offer some of the highest quality products at the most competitive prices on the market.

Their in-house design team is fully qualified in all aspects of design and production and they constantly aim to supply innovative, stylish and cost-effective hardware solutions settling for nothing less than top quality. Design facilities at their head office means they can create, manufacture and deliver state-of-the-art products to stay in-tune with current design trends and ahead of the competition.

The Zoo Hardware product ranges cover all aspects of architectural ironmongery, including: Vier – a precision design range of levers, hinges, door closers, DIN locks and cylinders created for the exacting needs of Architects, Specifiers and Contractors; Fulton & Bray – traditional and classic brass door hardware and accessories ideal for period and contemporary properties; Rosso Maniglie – an Italian inspired zinc designer lever and accessories range perfect for home owners and housebuilders; and Foxcote Foundries – a wide range of traditional black antique door furniture and window fittings.

View their full range of products at: [www.zoohardware.co.uk](http://www.zoohardware.co.uk) or call one of their friendly sales team on: +44 (0)1228 672900 to discuss your requirements or to request a catalogue.

**F & B**  
FULTON & BRAY  
FINEST BRASSWARE

**FF** Foxcote Foundries  
Decorative Castings

**WINDOW FURNITURE RANGE**

Our range of window furniture provides an array of styles and finishes that are ideal for period and contemporary properties alike. Whether you're looking for the perfect fittings to compliment your renovation project or in need of some classic accessories to finish your masterpiece, our Fulton & Bray finest brassware and Foxcote Foundries black antique ranges have everything you need for both sash and casement windows.

T : +44 (0) 1228 672 900  
E : sales@zoo-hardware.co.uk  
W : www.zoohardware.co.uk

Both Fulton & Bray and Foxcote Foundries are part of Zoo Hardware Ltd.

**ROSSO MANIGLIE**  
ELEGANZA CON STILE

**FINE ITALIAN DESIGN**

Rosso Maniglie is our exclusive range of Italian inspired designer levers. Produced using a zinc base material and manufactured to the highest standards, this range takes designer levers to the next level.

Created with a sleek and incomparable aesthetic appeal, our contemporary style Rosso Maniglie range has quickly become the first choice for home owners, architects and house builders throughout the UK.

T : +44 (0) 1228 672 900  
E : sales@zoo-hardware.co.uk  
W : www.zoohardware.co.uk

Now available in powder coated black finish and e-coated bronze finish.

Rosso Maniglie is part of Zoo Hardware Ltd.

**ADJUSTABLE CLOSING SPEED**

**ADJUSTABLE LATCH SPEED**

SUITABLE FOR DOORS UPTO **60KG** & 950MM WIDE

**10 YEAR MANUFACTURER WARRANTY**

**SIZE 3 FIXED POWER**

OUR VIER SIZE 3 FIXED POWER DOOR CLOSER IS SUITABLE FOR BOTH INWARD AND OUTWARD OPENING DOORS. CERTIFIRE APPROVED AND TESTED TO BS EN 1154 AND BS EN 1634.

T : +44 (0) 1228 672 900  
E : sales@zoo-hardware.co.uk  
W : www.zoohardware.co.uk

vier precision design

Vier is part of Zoo Hardware Ltd.



# Over 25 years of engineering excellence

GLW Engineering was first established in 1992 as Joe Bloggs Engineering by Geoff White and his business partner. After they parted ways, Geoff and his wife continued running the business, which became known as GLW Engineering in 1997. Currently based in March, East Anglia, the company prides itself on being a construction industry specialist, celebrating over 25 years of business and extensive engineering experience and expertise.

Operating in an extensive range of areas, GLW Engineering can provide staircases, handrails, platform, structural steelwork, shot blasting, sand blasting, soda blasting, and most recently powder coating. They are able to powder coat aluminium, mild steel, galvanised steel, and stainless steel. What's more, GLW Engineering can consult with their clients regarding bespoke requirements, creating one off solutions which are tailored to a customer's needs. These clients can include single self-builders as well as larger companies and contractors.

Indeed, GLW Engineering has experts in all areas of their business, and use 3D CAD design facilities. Where they truly shine, however, is in custom build objects in mild steel, aluminium, and stainless steel, all of which are built to the highest standard.

One of the company's most highly sought after services is shot blasting, which prepares steel work for a protective coating to be applied. By removing surface contaminants, it creates a surface profile for increased coating adhesion.

Their soda blasting technology is suitable for cleaning timber, wood, oak beams, oak floors, doors, stairs and bannisters, cars, boat hulls, masonry, food processing equipment, and structural steel. It will efficiently remove and clean multi-layered surfaces right down to the base, eliminating the need of toxic chemicals, scraping, sanding, or abrasive blasting. Soda blasting is safe to use on metal, fibreglass, glass, chrome, rubber, and trim, and can degrease and remove paint without damaging or distorting metal.

We had the pleasure of speaking to Geoff White, Managing Director, about what makes GLW Engineering stand out from the competition. "We are a family-run business, offering quality as well as quantity. We are always proud of what we do and have a passion to continue doing it well into the



future. Our main goal is to maintain our high quality services and to strive for longevity.

"A key advantage of GLW Engineering is the fact that we don't specialise in one thing, meaning we are always busy. We can offer engineering excellence in a large range of areas while consistently focusing on quality and a passion for what we do. In our eyes, the customer always has to come first, and so our service is second to none."

Certainly, it seems that the only way is up for GLW Engineering. After moving to new workshops six years ago to accommodate their growing trade, the company is now running out of space and looking to expand again due to an ever-increasing customer base. If you would like to find out more information on their full range of services, head to their website or use the contact details below.

**Contact**  
**T +44 (0)1945 464637**  
**info@glwengineering.co.uk**  
**www.glwengineering.co.uk**



## MossCreek: Expert Designers of Rustic American Homes

MossCreek was established in 1983 by Allen Halcomb, who fell in love with home design while at school. We had the pleasure of speaking to Allen, and it was clear during our conversation that he has a passion for designing beautiful homes and a firm belief that

a person's home is a part of who they are. Now, Allen's company MossCreek designs beautiful rustic American-style homes, providing customers with the opportunity to customise their house as much or as little as they desire.

Based in Knoxville, Tennessee, MossCreek offers their services to customers across the globe. Over the years, they have developed a signature style, using historical designs from different regions around the USA and blurring these together to create a fun, new style.

Made from natural, earth created materials as much as possible, MossCreek's homes are created using two different methods, both of which result in a beautiful and personalised home. One of these is an entirely bespoke design process, where a customer begins with a blank piece of paper, and MossCreek works with them to create a new and unique home design entirely from scratch. Their other method is using their library of pre-designed home plans, which can be purchased and modified to suit a customer's needs.

"We try and make the process as enjoyable as possible," Allen tells us. "We offer stylish design and a straightforward process; many architects and home builders have a very complicated process, but MossCreek excels at streamlining the process so homeowners can enjoy the progression of quickly realising their dreams."

Indeed, the purchase of a home is the single largest investment in life, so it makes sense to spend time and money making sure it is everything you always wished for. "A fine house is like fine art. We believe people should spend time choosing something brilliant, a home is part of your identity and shapes who you are, so we are passionate about making sure a customer gets their dream home."

If you would like to find out more information and see examples of MossCreek's beautiful home designs, head to their website. Alternatively, get in touch using the contact details below.

**T +44 (0)203 290 2986**  
**info@mosscreek.net**  
**www.mosscreek.net**



### Committed to superior quality & results

Created over 10 years ago to provide a complete building service for our clients. Lofts and Extensions are more than just a local builder. We will work with you to discover the full potential of your home and offer a one-stop shop for your project, from the creative planning stages right through to completion.

Our speciality include:

- **Extensions**
- **Loft Conversions**
- **Kitchen Design**
- **Bathroom Design**

Please call **07704 515415** or email **info@blonzer.co.uk**





## The small things make the biggest difference

You can tell a Rapieststar screw because each one has a unique 'Tri-Thread' hallmark stamped on its head. This is the real mark of performance and quality but is not the only assurance you get with a Rapieststar product.

Celebrating 25 years of design, development and supply of specialist fasteners and fixings, 75% of screws now used in fenestration in the UK and Ireland are Rapieststar products.

This is because, over the last quarter century, Rapieststar's primary objective has been to support its customers with quality of service and products that



allows its customers to carry out their projects with minimum of fuss.

Rapieststar's family of award-winning screws and fasteners include Starpcu window screws, Starfix direct masonry fixings and Starturn universal wood screws, which also carry CE Marking with full Declarations of Performance and go beyond UK and European quality and performance standards.

There is a huge advantage in using a credible supplier like Rapieststar. Not only do they supply products with all of the necessary accreditations and proof, Rapieststar

is also fully knowledgeable in all of the requirements of new and existing quality and security regulations.

If you have previously bought fasteners and fixings primarily on price, you may need to review your supply arrangements and ensure a reliable supply of correctly tested and approved components, or risk having a product that doesn't meet the standard.

T +44 (0)1260 223311  
info@rapierstar.com  
www.rapierstar.com

## Pizza Oven Supplies: Bringing the tastes of Italy straight to your garden

Pizza Oven Supplies is managed by husband and wife team Nick and Sam Riley. With 26 years' experience in the building trade, Nick began making wood burning ovens five years ago, before creating the business a year later.

He decided he wanted to learn how to make these ovens and began researching the best materials and methods to do so. Nick eventually discovered that Stoke-on-Trent, where the company is based, had been building bottle kilns for years, and a wood burning oven is a type of bottle kiln. After experimenting with different mixes, he managed to build a successful oven and decided to create a mould for his finished design. This led to him developing a website, and he began travelling up and down the country building wood burning ovens for various customers.

As the business grew, he decided to put all his knowledge into creating kits for people to build the ovens themselves, or have them built by someone with more experience. These kits come with pre-cut bricks, along with drawings and in depth instructions to help designers, builders and DIYers. As well as the kits, Nick offers expert advice every step of the way, so customers can be confident that they will be happy with the finished product.

We spoke to Nick about his unique services and products. "The kits we sell contain all of the materials, instructions and drawings you need in order to build your own wood burning oven. A lot of our materials are recycled from the pottery industry, which keeps costs down while still using high quality refractory materials. Furthermore, all of our ovens are 100mm thick, which creates a

more substantial oven and therefore more value for money."

Their most popular oven is the Milan 750, an ideal domestic oven which can still be used in commercial projects. This easily cooks two 10 inch pizzas at a time, and the user can build their



own design around it. Pizza Oven Supplies have also recently released the Tuscan 650, which is designed to be built and be ready for use on the same day.

Pizza Oven Supplies has recently opened a showroom and moved into a larger factory. This means they can boost their output to keep up with the ever increasing demand for their oven kits. They are constantly developing new ovens and designs, and creating new moulds in order to reduce production time yet maintain the high quality of their products. For more information, head to their website, or use the contact details below.

T +44 (0)1782 212777  
info@pizzaovensupplies.co.uk  
www.pizzaovensupplies.co.uk

**ROSSO MANIGLIE**  
ELEGANZA CON STILE

**FINE ITALIAN DESIGN**

Rosso Maniglie is our exclusive range of Italian inspired designer levers. Produced using a zinc base material and manufactured to the highest standards, this range takes designer levers to the next level.

Created with a sleek and incomparable aesthetic appeal, our contemporary style Rosso Maniglie range has quickly become the first choice for home owners, architects and house builders throughout the UK.

T : +44 (0) 1228 672 900  
E : sales@zoo-hardware.co.uk  
W : www.zoohardware.co.uk

For further information on this range visit our website or call one of our friendly sales team.

Rosso Maniglie is part of Zoo Hardware Ltd.

## Interiors News



## NoCode Brassware

UK based NoCode curates tap and showering solutions, chosen for their beautiful design and superior quality. All brassware products are designed and made in Italy and undergo rigorous testing to ensure consistent high quality and enduring performance. NoCode offers a wide selection of designs, colour finishes and installations. EcoAir options are available for shower installations where water conservation is a key issue.

look with on trend colour finishes available, and a plating service offered for more customised looks. Different handle options also add to the versatility in terms of design. Shower valves are on an ultra slim 70mm back plate and the new Versobox Plus is even more minimalist with valves on individual trims for a stunning look. The performance element is impressive with a 2 outlet shower valve delivering 39.6lt/min at 3 bar water pressure.

The NoCode Versobox shower valve is ideal for a co-ordinated bathroom

T +44 (0)20 8685 6815  
www.nocode.co.uk



NoCode

020 8685 6815  
www.nocode.co.uk



# Bespoke, waterproof and long lasting basements

Glatthaar-Fertigkeller Ltd was first set up in 1980, boasting almost 40 years of experience in the industry and now delivering 5,000 basements a year. From their headquarters in Germany, Glatthaar develops innovative and bespoke basements which offer the very best in reliability and durability. The company operates across the whole of Europe, with their basements installed in homes and buildings far and wide.



Unlike your typical contractor, Glatthaar is dedicated to providing the best service for their customers and ensuring their basement is as long lasting and stable as possible. Whether it's for an extra room, a storage space, a DIY workshop space, Glatthaar can build the best basement to suit your needs.

As one of the leading prefabrication basement specialists in the UK, Glatthaar



**CORDURA**  
Fabric

FROM THE BATTLEFIELD TO THE WORKSITE...

**RUGGED RELIABILITY**

Wherever the challenge, you'll find footwear made with CORDURA® fabrics. Engineered to deliver enhanced abrasion resistance and tear strength, with exceptional strength-to-weight ratio.

Worn by people pushing their limits - in the field, on the job, at the construction site.

- ABRASION RESISTANT
- BREATHABLE
- TEAR RESISTANT
- HARDWEARING
- BUILT TO LAST

CORDURA.COM

is able to provide an insurance backed warranty against water ingress. Most commonly entering through the wall to floor joints, water entry can cause water stains and leaks within the basement. Once inside, repairing and preventing further ingress can often be complicated and costly. Thankfully, Glatthaar is able to guarantee water tightness with zero ingress, and last year, the company finalised an agreement with insurance partners Buildzone to guarantee this.

The waterproof AquaSafe® basement features precast concrete panels, additional tanking of external walls to prevent seepage, the AquaSafe® basement is 100% guaranteed waterproof. For those really curious, Glatthaar even has a floating house where you can see the basement in action.

In addition to bespoke basements, Glatthaar also has a Baby Basement which provides additional space at a fraction of the typical cost. Ideal for those seeking a storage or utility room, this particular basement features a basement slab, twin panel external walls and a reinforced concrete ceiling. Quick and easy to set up, inexpensive, and providing the perfect extra space for everything from storage to wine cellars to study space, the Baby Basement has proven highly popular across the country.

During the entire process, Glatthaar works closely with the customer to ensure the basement is coming along exactly as they envisioned. Whether it's a basement that mirrors the floor space of the entire house, or is larger, or even shorter, the end goal is always complete customer satisfaction. Better yet, Glatthaar also provides a personal point of contact for each customer, meaning they can stay updated regarding the progress of their basement.

If you would like to find out more about Glatthaar and how they can help you build the basement of your dreams, be sure to get in contact with the team using the details below. More details on their many different basement styles and bespoke service can also be found online.

Contact  
T +44 (0)1932 344454  
[www.glatthaar.com](http://www.glatthaar.com)





# Industry-leading experts in Magnetic Filtration

ADEY was established in 2003 by Chris Adey, the inventor of the MagnaClean magnetic filter. Since then, ADEY has witnessed impressive growth on a global scale, now working across Europe, China and North America, garnering an international reputation for superior products and services.

ADEY is committed to preventing heating system breakdowns, dedicating their time to developing innovative products and industry-leading technology to help with this. Offering comprehensive solutions for protecting heating systems, ADEY provides water treatment, chemicals, and scale reducers, on top of their world-leading MagnaClean filters. These magnetic filters attract the iron oxide sludge that forms inside heating systems, which can lead to boiler breakdowns, helping to maintain heating



systems in both homes and larger public buildings. What's more, ADEY offers their Best Practice guide, which involves six steps to ensure optimum and long lasting protection of heating systems, all of which can be completed with ADEY's range of products.

Always at the forefront of innovation, ADEY recently launched its MagnaClean Professional3 Sense®, the only Wi-Fi enabled connected magnetic filter on the market. Its unique Sense® technology ensures high performance system protection, and predicts potential problems in the heating system before it breaks down, allowing for preventative maintenance. For homeowners this means huge savings in time and cost, as well as the reassuring knowledge that their heating system is well maintained and therefore less likely to fail. Indeed, ADEY is working on releasing even more



technology with similar remote control functions to increase the presence of preventative maintenance technology in the marketplace.

Another product of note is the MagnaClean Atom™, a super compact filter which can be fitted into previously inaccessible spaces. Certainly, ADEY is

committed to ensuring as many people as possible can benefit from their market-leading technology.

Offering products for both domestic and commercial usage, ADEY offers unrivalled expertise in magnetic filtration, and is known internationally for its innovation and commitment to bringing value to the

market with new and better products year on year. If you would like to find out more information, head to their website or use the contact details below.

**Contact**  
T +44 (0)1242 546714  
[andrew.hearn@adey.com](mailto:andrew.hearn@adey.com)  
[www.adey.com](http://www.adey.com)

**ADEY**

**NEW**

## The one to fit where others don't

- Super compact, space saving filter
- Developed to provide effective magnetic filtration in the tightest of installation spaces
- Filter can be switched to bypass when servicing
- 115mm total space required

2 minute installation    Bypass 180 degree    Vertical and horizontal installation

Fits in the tightest of spaces    Space saving for simple servicing

To find out more head to [adey.com/atom](http://adey.com/atom) or call 01242 546717

**MagnaClean™**  
Atom



## Multiple new customers with £3 million sales secured

TC Facilities Management (TCFM) has secured multiple new customers for the delivery of Cleaning & Window Cleaning Services in the Wholesale, High Street & Commercial Office sectors across the UK.

The contracts, worth £3 million per annum, will see over 300 colleagues join TCFM up and down the country since the contracts started going live from 1st March, 2019.

The Operations team from TCFM, jointly led by Jason Smith, Head of Operations for Scotland and Cosmin Tecuta, TCFM Contract Director, will deliver cleaning services to over 100 sites for 14 new customers.

The contracts have been awarded based on TCFM's proven track record spanning over 55 years, along with their ability to listen to the bespoke needs of each customer towards delivering what is really needed.

As one of the UK's top cleaning services providers the new operating environments will benefit from TCFM's rigorous systems and state-of-the-art technology to help maintain and improve standards in each site along with delivering robust monitoring and management reporting to each customer.



Keith French, Business Development & Strategy Director, TCFM, who led the contract win said, "We are delighted to have been awarded these contracts and are looking forward to bringing our proven expertise to each and every customer along with playing our part in making each site a great place to work & visit."

Contact  
T +44 (0)1737 814016  
info@tcfm.co.uk  
www.tcfm.co.uk

## TC Security Services safeguarding Avison Young

Since early January 2019, TC Security Services, part of TC Facilities Management (TCFM), have been providing guarding and mobile patrol services to Avison Young (formerly GVA). The portfolio, covers multiple and diverse locations across London and the South East.

TC Security Services welcomed 20 new colleagues to the business from a number of incumbent suppliers.

The contract commenced on 2nd January and client feedback about the mobilisation, led by Patrick O'Sullivan, Operations Manager, is very positive.

Alan Prince, Director, National Strategic FM for Avison Young commented, "We ran a full-blown tender to make sure we appointed the right security specialist to manage this diverse portfolio of properties. Against a wide range of criteria, TC Security Services came out in front. As a new supplier, there was an added element of risk, but nearly four months after go-live, we're delighted with the decision to appoint them."

In response to the award, Satia Rai, Operations Director of TC Security Services said, "Having been awarded the contract for guarding and mobile patrol services with Avison Young, we committed the resource necessary to ensure the mobilisation was seamless. We've implemented best in class



technology that will provide TC Security Services and Avison Young with data and analysis to shape better decision making."

Tony Reed, CEO of TC Facilities Management added, "This award is a great result for the business and demonstrates ongoing growth for TCFM as a whole. We look forward to being Avison Young's partner of choice, adding value and providing the expertise that Avison Young need each day."

Contact  
T +44 (0)1737 814016  
www.tcfm.co.uk

## Celebrations with a lot of heart



We're all celebrating smashing the TCFM £5K challenge, after just 5 1/2 months of the charity partnership going live.

This has been achieved through a number of activities, but most notably bagging up unwanted toys, clothes, CDs,

books, DVDs and a whole host of other household items that are then sold in the BHF charity shops across the country.

Everyone has tried to get on board to help our charity partner, the British Heart Foundation. They conduct ground-breaking research in to heart and circulatory diseases and their causes.

The remainder of the year will see colleagues at TCFM continue with the BHF's Bag it! Beat it! campaign along with other activities that are being planned on a more local basis.

BHF were selected by TCFM as a way of providing more than just their specialist services to the charity's network of Furniture and Electrical stores where we professionally clean every item of donated soft furnishing.

T +44 (0)1737 814016  
info@tcfm.co.uk  
www.tcfm.co.uk

## TC Security Services awarded 100% Achilles Audit



Following a rigorous 2-day assessment, TC Facilities Management (TCFM) has once again successfully completed their 'Achilles' annual audit for the fourth consecutive year.

The audit saw a score of 100% being awarded in all four key areas that the audit measures: Corporate Social Responsibility, health and safety, environment, and quality.

This 100% achievement validates TCFM's operational capability, competence and compliance.

The two-day visit included an audit of both head office and a client site.

The auditor was particularly impressed by:

- ▲ The breadth of documentation to evidence the quality management systems in place
- ▲ The ongoing commitment to our duty of care of our colleagues by investing in innovative technology
- ▲ The design and navigation of the training matrix in use
- ▲ The use of the site visit report which captures the four key areas that the audit measures
- ▲ Our down-to-earth approach, doing what we say we do in a straightforward and uncomplicated way.

At the site audit, the auditor commented about the appearance, attitude and knowledge of security officers to ensure the job they do is done to the very best of their ability.

This accreditation follows the recent news that TCFM achieved a clean sweep in passing three external management systems audits including the new ISO 45001:2018 standard.

T +44 (0)1737 814016  
sales@tcfm.co.uk  
www.tcfm.co.uk

## Quality audits score a clean sweep

Following a rigorous 2-day assessment, TC Facilities Management (TCFM) has successfully passed three external management systems audits including the new ISO 45001:2018 standard. This and the other new 2015 versions for ISO 9001 and the Environmental audit ISO 14001 were all passed without any non-conformities or observations, emphasising the commitment of TCFM's senior management to these standards.

The audit took place over two consecutive days and included a comprehensive review of company policies and processes. This was to assess TCFM's approach to the quality (ISO 9001) and safety (ISO



45001:2018) they provide to their customers and colleagues, as well as the measures they take to minimise TCFM's environmental impact (ISO 14001) from their operations.

The new ISO 45001:2018 is believed could help, on a global level, save more lives, reduce accidents further and improve employee morale. Organisations have until March 2021 to make the transition to the new standard that came in 2018, replacing the BS OHAS 18001:2007. TCFM's achievement in making the transition to the new standards is testament to the work of TCFM's Compliance Manager Richard Grafham who championed the transition. It also emphasises the senior management's commitment to these standards.

Contact  
T +44 (0)1737 814016  
info@tcfm.co.uk  
www.tcfm.co.uk

## TCFM and BHF partnership shortlisted for prestigious Cleaning Award

TC Facilities Management (TCFM) has reached the finalist stages of the Corporate Social Responsibility category, CSSA Awards 2019.

This is for their work with the British Heart Foundation; the charity that conducts ground-breaking research in to heart and circulatory diseases and their causes.

The winners will be announced at an invitation only lunch event next month. This took place at the Cleaning Show on Wednesday 20th March, 2019 in London.

The CSSA awards recognise and reward excellence and effectiveness across many sectors of the UK Contract Cleaning Industry. They acknowledge everything that shines within the UK cleaning sector.

TCFM's approach has helped the British Heart Foundation raise funds for their life-saving research. This has been achieved by the services they provided



in their Furniture and Electrical stores and being only a hair-breath's away from achieving their annual fundraising challenge of £5K. This has taken just over 4 months, since the National Charity agreement started in September.

Contact  
T +44 (0)1737 814016  
info@tcfm.co.uk  
www.tcfm.co.uk

## Donations are in the bag for British Heart Foundation

TC Facilities Management (TCFM) have created a national charity partnership to help the British Heart Foundation achieve its aim of beating heartbreak forever. The partnership commenced 6 weeks ago and has set its sights on raising £5K of funds for the charity that conducts ground-breaking research in to heart and circulatory diseases and their causes.

Heart and circulatory diseases kill 1 in 4 people in the UK, causing heartbreak in every street. Fiona Ellingham, Marketing Manager, TCFM has had a number of family members affected by heart conditions including a niece who required a heart transplant aged just 5 and a brother who thanks to a



special pacemaker, his heart is able to maintain a stable rhythm to keep him alive.

"Speaking with other colleagues at TCFM, it became very apparent that I was not alone in having family members affected and so the partnership was born."

"At the moment, our colleagues are busy having clear outs at home and filling bags with unwanted items that can be sold in the BHF stores across the country. In the last 6 weeks colleagues from all over the country have collected more than 50 of the 300 (minimum) bags of items we're aiming for."

"We have a number of other activities planned through the year that will not only raise funds for BHF but will also train people in how to do CPR, something which saved my brother's life over 2 years ago."

T +44 (0)1737 814016  
www.tcfm.co.uk

## A hat trick that our clients will tell you is well deserved

TC Security Services, part of TC Facilities Management (TCFM), have not only been placed in the top 2% of all SIA listed companies within the Approved Contractor Scheme in the UK, they have also passed the ISO 9001 and 14001 management systems audits which came in to force last year.

The 4-day visit by both auditors involved full scrutiny of the TC Security Services operation and for the ACS audit included visiting both the Head Quarters and satellite offices along with a mix of varied customers.

The maximum overall score on the ACS audit that can be achieved is currently 175 points. TC Security Services' score of 164 places them not only in the top 2% of all SIA listed companies within the Approved Contractor Scheme, it also showed an increase in the score awarded by the auditors in 2017. All this shows TC Security Services as one of the very best security companies in the entire country.

Coupled with this was passing the ISO 9001:2015 and 14001:2015 management systems audits. This



was the fourth time these new quality standards came in to effect September 14th last year which have been audited and passed each time.

T +44 (0)1737 814016  
info@tcfm.co.uk  
www.tcfm.co.uk



# Are you looking to create more living space for a fraction of the cost of extending?



Warwick Buildings Ltd have been constructing timber sectional buildings for over 30 years. We are one of the market leaders in supplying timber garden offices and garages around the whole of the UK. We are a friendly and innovative company, winning Small Business of the Year for Warwickshire twice.

Based in Warwickshire, Warwick Buildings construct



all their own buildings at their manufacturing site, using environmentally-friendly timber sourced from Scandinavian forests, through companies registered with the FSC and PEFC (Programme for the Endorsement of Forest Certification).

Warwick Buildings' offices part of the business was launched around 10 years ago, beginning with our

Traditional Office, which has a cottage-style feel. We have continued to expand our range in line with the market, introducing the Contemporary and Modern offices and our uniquely designed Curved Roof office. Our most recent additions to the range are the budget Pod offices.

All offices are fully insulated and have first fix electrics included and come with a range of different roofing, door/window and cladding options.

The timber garages come in a range of sizes in Shiplap or Feather-edge cladding, with different options for roofing and doors.

By combining practicality and aesthetics, Warwick Buildings provide and attractive, invaluable addition to your living and working space.

For further information visit our website: [www.warwickbuildings.co.uk](http://www.warwickbuildings.co.uk) or come to our show site at Long Itchington in Warwickshire, where you can see a selection of our buildings.

## Halo 80 Plus blast protecting litter bin

Energetics Technology Ltd are experts in the design and manufacture of blast protection systems. Our blast protecting litter bins complement protective street furniture and help to enhance, and protect, our shared spaces.



Located in mixed use spaces, commercial areas and transport hubs our litter bins have home office accreditation for the mitigation of explosive threats. The merging of public/private spaces requires increased security and counter terror capability. Energetics Technology's products provide this capability whilst remaining practical, easy to use and simple to install.

Utilising Energetics Technology's unique SabreMat composite, the bins contain the effects of explosive charges placed within the bins. Tested with both fragmenting and plain charges, the bins ensure all blast and shock waves are directed upwards, not sideways. Thus, providing protection for any members of the public who may be near the bin at the time of a charge initialisation.

Traditionally it has been a requirement to permanently fix the bin to the ground to provide stability, should an explosive event occur in the bin. However, a recent addition to the product range, the Halo 80 Plus, is not required to be fixed to the ground. Its novel design ensures the bin remains upright whilst subjected to the effects of a blast. This allows the Halo 80 plus to be sited in internal locations such as shopping malls, arenas and airports. It also means that the bin is portable and can be re-sited should threat points change.

Used throughout the world in key infrastructure projects, Energetics Technology's blast protecting litter bins are part of a range of products that include threat isolation units, blast mitigation units, explosives transport containers and explosive storage and packaging solutions.

If you require more details of the blast protecting litter bins, or wish to discuss your project with the team please contact the team at: [enquiries@energetics-technology.com](mailto:enquiries@energetics-technology.com), call us on: +44 (0)1283 732339 or visit our website at: [www.energetics-technology.com](http://www.energetics-technology.com)

## TIMBER GARDEN BUILDINGS



GARDEN OFFICES  
TIMBER GARAGES  
WORKROOMS



WARWICK BUILDINGS  
NIGHTINGALE LANE  
LONG ITCHINGTON  
SOUTHAM  
CV47 9QL  
01926 815757

[www.warwickbuildings.co.uk](http://www.warwickbuildings.co.uk)

## THE BEST PLACE TO GET QUALIFIED PRODUCT INFORMATION FOR BUILT ENVIRONMENT PROJECTS

ESI.info has been helping busy professionals create better environments for over 25 years. We believe that whether it happens to be outdoors, indoors, commercial, industrial, public or residential, every great environment is based on sound decisions about who to work with and what materials to use. We're here to support better and faster decision making.

Visit ESI.info today to find the best products and companies to work with for your next project.



ESI.info | better decisions for better environments  
[www.esi.info](http://www.esi.info)

Telephone: 0131 586 4466

## HEDGE TRIMMERS Suitable for Mini-Diggers

### HC150

Bar Length-1.5m  
Excavator Range-1.5-3T



### HC180

Bar Length-1.8m  
Excavator Range-3-7T



### FH100

Twin Cut Flail  
Suitable for Mini-Diggers  
from 2.5 up to 8t  
1m Cut Area  
Suitable for cutting grass,  
scrub and undergrowth



### HS75

Blade Diameter 750mm  
Will cut up to 10"  
Excavator range 3.5t-8t

### HT1000

Diesel/Petrol  
Tracked Dumper



Please contact: 00353 469024858 • Email: [slanetracsales@gmail.com](mailto:slanetracsales@gmail.com)  
[www.slanetrac.ie](http://www.slanetrac.ie) • Dean Hill Hayes, Navan, Co.Meath, Ireland



**Need a bin?** We've got just the thing  
Flip, swing or multi-compartment, innovative all-plastic sack holders to sustainable hardwood external bins.

Call us now on **01684 295782** [www.trojanbins.com](http://www.trojanbins.com)  
email: [sales@trojanbins.com](mailto:sales@trojanbins.com)





## Wonderwall: Modern planters for indoor or outdoor use

Wonderwall are one of the UK's leading producers of unique decorative garden products, comprised of a skilled team of passionate designers. They are most renowned for their planters, for use indoors and outdoors, and which can be used to create an array of stunning designs. Each planter is easy to use and resilient to all weather types in light of the planters' durable and weather proof material. Wonderwall's ground-breaking design has allowed gardeners to bring life back into a drab urban space, transforming the bleak into the beautiful.

The planters not only look stunning, but are also unrivalled in their design, providing a self-watering



function that enables gardeners to maintain large displays with little upkeep. This allows them to focus their attention on the look of the wall, bringing their imaginations to life and creating their own masterpieces.

The company have truly revolutionised the simplicity of producing a fantastic, potted wall that brings the wonder of nature into any modern space. So if you would like to get your hands on one of Wonderwall's vertical planters, take a trip to your nearest garden centre. For any further enquiries, or if you would like to get in contact with Wonderwall, feel free to telephone them on the number to the right.



T +44 (0)161 643 5742  
[sales@uspcreations.com](mailto:sales@uspcreations.com)  
[www.wonderwall.direct](http://www.wonderwall.direct)

## Resin Bound: The permeable driveway everyone is asking for!



Resin Bound is the fastest growing surfacing application of the last 5 years and is ideal for commercial and residential use. It is being embraced by specifiers, developers and surfacing contractors who recognise the sales opportunity it represents.

Permeability is a major plus point. Fully SUDS compliant, resin bound meets planning requirements – making it ideal for new builds and renovations.

It is also a stunning alternative to block paving, macadam concrete or loose gravel and, thanks to its hard-wearing, natural finish, it ticks many of the boxes customers want regarding appearance, longevity and low maintenance.

**DALTEX UVR system is BBA accredited**  
 Derbyshire Specialist Aggregates is the manufacturer of DALTEX dried aggregates, the UK's No 1 brand for resin bound.

DALTEX dried aggregates are meticulously dried and screened to produce a high quality product which combined with DALTEX UVR resin deliver a beautifully consistent finish.

The DALTEX UVR resin bound System has been awarded certification by the BBA (the British Board of Agrément). The Certificate is recognised by building control, government departments, architects, specifiers and industry insurers. It's a mark of quality, safety, reliability and fitness-for-purpose.

Derbyshire Specialist Aggregates offer the largest range of aggregate colours, sizes and shapes and the new DALTEX Bespoke range consist of 40 stunning colour blends – from rich reds to stylish greys to soft golden browns.

The company offers 100% stock availability and keeps thousands of tonnes of raw material and finished product ready for next day delivery – nationwide.

Derbyshire Specialist Aggregates is committed to promoting the very highest installation quality and runs a one day resin bound training course from purpose built facilities in Derbyshire.

T +44 (0)1629 636500  
[sales@derbyaggs.com](mailto:sales@derbyaggs.com)  
[www.resinbondedaggregates.com](http://www.resinbondedaggregates.com)

**RESIN BOUND**  
 THE DRIVEWAY SURFACE  
**EVERYONE**  
 IS ASKING FOR!

- Permeable paving system. SUDS compliant
- Perfect for driveways, patios and paths
- The largest range of colours available
- Come direct to the manufacturer of DALTEX dried aggregates
- BBA accredited DALTEX dried aggregates and UVR resin - the highest standard available

Introducing...  
**Daltex Bespoke** 40 Stunning new resin bound blends  
 Colours customers are bound to love!

**The No.1 Choice for All Resin Bound Installations**

derbyshire specialist aggregates

01629 636500  
[resinbondedaggregates.com](http://resinbondedaggregates.com)

Arbor Low Works, Youlgrave, Bakewell, Derbyshire, DE45 1J5

**BBA** APPROVED MANUFACTURER CERTIFICATION



## ADEY's new connected filter is 'game-changer'

The industry's first and only Wi-Fi connected predictive magnetic filter, the new MagnaClean Professional3 Sense, has been launched by ADEY, the pioneer of magnetic filtration technology.



The development is the biggest innovation in magnetic filtration and heating system care since ADEY invented the first MagnaClean 15 years ago. The new filter not only provides high performance system protection, it also predicts potential system problems and offers connected preventative maintenance.

Using ADEY's unique Sense technology, the filter detects the level of magnetite collected, preventing ongoing system damage by alerting installers so problems can be treated before it's too late.

MagnaClean Professional3 Sense incorporates ADEY's proven filter performance and benefits, with the addition of Wi-Fi and battery-powered monitoring technology enabling it to self-detect how much sludge has been captured and removed from circulation.

It takes a reading every 12 hours for the first two weeks after installation or servicing, then once every five days, helping to prolong battery life of up to two years. Using Wi-Fi, this information is communicated to the installer through the ADEY ProClub App. An annual service reminder is also delivered in this way.

For more information on ADEY's latest magnetic filter, visit: [www.adey.com/pro3](http://www.adey.com/pro3)

T +44 (0)1242 546700  
[info@adey.com](mailto:info@adey.com)  
[www.adey.com](http://www.adey.com)

## The future of underfloor heating

As history demonstrates, if a company is to become an industry leader, a focus on innovation and disruption needs to be at the centre of their business model.



"Innovation distinguishes between a leader and a follower." Steve Jobs

For CircoFloPro, the concept of innovation has become the heart of their company. Using three primary elements of calculability, efficiency and predictability, CircoFloPro guarantees that they continue to develop their product/service towards ease of installation, product excellence and meeting the needs of the end user.

### Efficiency

From the point of purchase, CircoFloPro is different. Their specially designed quick quote app means it's as easy as measuring the room and inputting the details to get a price. Eliminating the need to negotiate for a price or waiting 2 to 3 days before receiving a quote.

With patented lay fast technology, CircoFloPro is easy and quick to install. Unlike other emitters that have been known to warp during the installation of pipe, CircoFloPro is sturdy enough to be trodden on.

### Predictability

Other brands offer a varied range of pipe sizes with differing centres to their emitters, increasing the chance of faulty installation.

With a focus on a simple answer to UFH, CircoFloPro has completely standardised their product range. All emitters use the same 12mm pipe with 133mm centres, providing a consistent heat output across all products. No guessing if the product will work, because it just does. Removing risk and futureproofing any installation.

### Calculability

What's even better, is their pricing is commonly equal to or cheaper than its counterparts from other brands. Customer don't just save time by receiving a quote quickly, they save money!!

[www.circoflopro.co.uk](http://www.circoflopro.co.uk)

## Safer heating for SEN school

Safe surface temperature specialists, Contour, have recently completed a project with Walton Hall Academy to provide LST safety radiator guards to the school that will protect students from burns and reduce the risk of injuries around their radiators.

Walton Hall is a special educational needs school in Staffordshire. Their previous radiator covers needed to be replaced to allow staff easier access for cleaning

and maintenance as students were often pushing small items through the grilles.

With close consultation to their needs, Contour provided 19 DeepClean LST radiator covers with radius edges and bullnose corners, which eliminated the risk of children injuring themselves on sharp edges. The DeepClean design also features pencil proof grilles, which addressed another one of the schools problems.



To read more on this case study visit the Contour website at: <https://bit.ly/2IADhqf>

T +44 (0)1952 290498  
[www.contourheating.co.uk](http://www.contourheating.co.uk)

**circofloPro**  
**BESPOKE UNDERFLOOR HEATING THAT'S AS EASY AS A KIT**  
[WWW.CIRCOFLOPRO.CO.UK](http://WWW.CIRCOFLOPRO.CO.UK)

**iSmart**  
 ENGINEERING SMART HOMES  
[www.ismarthomecontrol.com](http://www.ismarthomecontrol.com)  
[hello@ismarthomecontrol.com](mailto:hello@ismarthomecontrol.com) | 01732 4220722

- Voice Control
- Design Services
- Intelligent Lighting
- Security
- Smart Building | Blinds
- Electrical | HVAC Services
- Multiroom Audio & Video
- Intelligent Heating & Cooling
- Automatic Lighting
- Circadian Lighting
- Visual Notification
- Movement Sensing
- Monitoring & Alerts
- Access Control
- Safety & Security
- Energy Efficiency



# Hauraton beat the competition at the Community Sports Complex in Doncaster

The Community Sports Complex in Doncaster has been imaginatively planned and built to the highest architectural standards. The development integrates sport and community facilities in a spectacular parkland setting. Doncaster Council is confident it will raise the town's profile locally, regionally and nationally and help to increase the numbers of local people watching and taking part in sport and other community activities.

At the heart of the complex is a 15,100 capacity community stadium that incorporates an 800 square metre supporters bar, plus a 350 seat restaurant, a gymnasium and martial arts centre. The stadium is complemented by a separate floodlit six lane athletics track with two eight lane straights and its own covered 500 seat mini-stand. Other facilities include two floodlit reinforced and grass sports fields, 11

floodlit all weather pitches for five and seven a-side team games, a 10 acre public park and a 1,000 space car park.

The location of the Complex has meant particular attention was paid to rainwater run-off and pipe depth issues in general. WSP Consulting Engineers were appointed for this part of the project. In discussion with main contractors



Carillion, it was decided to use Hauraton injection moulded polypropylene RECYFIX® SUPER drainage channels around the perimeter of the stadium. 640 metres of channel was eventually specified, plus a further 340 metres of pitch-side drainage inside the stadium itself. RECYFIX® SUPER was chosen for being strong yet light enough to comply with manual lifting regulations. Subsequently, 250 metres of same channel was also used to drain walkways and around the five-a-side pitches. Hauraton also supplied the components for the athletic track water jump and the long jump sand trap.

Being such a large environmentally sensitive area, the car park drainage system was a particularly tricky problem. Colin Taff, Hauraton Applications Engineer explains, "The larger sizes of Recyfix® Super channel were initially considered for the car park. However because of its position and relation to the nearby lake it was essential the depth of the system was kept to a minimum. It was realised there could only be one outlet at the end of each run, located to one side of the car park. Using RECYFIX® SUPER would have entail installing too many trash boxes and deep pipe drains therefore a high capacity channel was the only practical solution. After further consideration our newly introduced RECYFIX® HICAP® system was found to answer the problem perfectly."

Hauraton's Sales and Marketing Director, Tim Connolly was very pleased with the feedback from the contractors. "Carillion seemed to be impressed with the ease and speed of installing all our systems due to the one man lift capability. Calls from site during and after installation proved these benefits to be the case. Carillion's site agent was pleased with the speed at which all the RECYFIX® channels had been installed, even those that were cut to shape, this apparently saved many man hours. The installing teams were also very happy 'much easier on my



back' and 'a lot less fiddly to install' were their comments. Asked how the Recyfix® products compared to other channel systems, the overwhelming response was; it was far better than larger, heavier units made from concrete and polymer materials because they enabled simplified installation procedures."

Tim concludes, "We are delighted that all concerned in the project found our product so 'installer friendly' and that the massive investment Hauraton have made in recent years in new products has been justified with much lower installation costs for contractors, as proved on the Doncaster project."

T +44 (0)1582 501380  
www.hauraton.co.uk



## INTRODUCING... THE PIPE COWL FAMILY

The Quickest, Neatest, Simplest and Lowest Cost installation solution for pressure relief termination

### THE PIPE COWL



Pipe Cowl Available in 15mm & 22mm

### EXTENDED VERSION



FOR EASY HIGH LEVEL INSTALLATION!  
Extended Pipe Cowl available in 15mm only

Only one soldered joint to make!

Proprietary fitting manufactured in copper to EN1254.

Complies with all current legislation and NHBC approved.

Guarantees a neat finish every time!

Patents: Europe – EP1 429 076 UK  
GB 2 396 204

For full details visit: [www.pipecowl.com](http://www.pipecowl.com)

### Compare the difference

<p>1 Pipe Cowl 1 soldered joint Neat finish every time Save 30 - 40 minutes</p>	<p>2 bends 1 tube 4 solder joints Every installation is different</p>
<p>Boiler External Wall</p>	<p>Boiler External Wall</p>

[www.clickfix.co](http://www.clickfix.co)



Call: 01384 442852 • Email: [rjweng@btinternet.com](mailto:rjweng@btinternet.com)

Part of the  
RJW Engineering Group.

[www.rjwengineering.co](http://www.rjwengineering.co)  
[www.pipecowl.com](http://www.pipecowl.com)



# Real, genuine parts for commercial and domestic appliances

UK Spares was initially established in 1993 by UK Electric Ltd. Based in Almondsbury, Bristol, they provide a wealth of spare parts that can be used in commercial and domestic applications across electric, water, and heating sectors.

The company have built up a reputation over the decades for their genuine and precise parts, and have come to be known as one of the most reliable suppliers across the UK. Operating both nationally and globally, their spare parts cover machinery within electric water heating and electric space heating, with all parts fully functional. In addition to their long running experience, UK Spares are part of UK Electric Ltd and as such have a number of sister companies across a broad range of sectors, such as electrical, mechanical, lighting and controls, all of which helps to inform UK Spares' own expertise.

When it comes to sourcing spare parts, many buyers often go for the cheapest option available, which is more often than not an alternative to the original. The part may look the same, function the same and be marked as compatible with the original machine in question. However these alternative parts can lead to rapid wear and tear, complications and breakdown of the appliance.

UK Spares can provide the genuine manufacturers parts for an ever growing selection of appliances and brands, such as Ariston, Beko, Bosch, Creda, Dimplex, Electrolux, Hotpoint, Karcher, Morphy Richards, Samsung, Triton, Whirlpool and Zip, with many more also available. They have thousands



of spare parts stocked, whether for convector heaters, cooking appliances, fan heaters, fridges and freezers, panel heaters, showers, towel rails, vacuum cleaners, water boilers and heaters, and ventilation equipment.

On top of the actual parts themselves, UK Spares also has an enviable knowledge base, and can assist clients with advice and guidance as to what the best spare part needed would be. They work primarily with electrical wholesalers, installers and electricians. With their expert advice, they have helped customers around the world get the parts they need to have their appliances up and running once again, facilitating home life or furthering their businesses.

There are a great many reason to opt for repair as opposed to replacing. Although it might seem easier to just replace a broken down item, this is far most costly and environmentally harmful in the long run. With just a simple parts replacement, you can extend the life of your appliance without shelling out for a whole new item. Additionally, this drastically cuts down on waste and landfill.

If you would like to get in contact and find out more about UK Spares' specialist spare parts, then do not hesitate to pick up the phone today. Alternatively, you can contact the company via email or you can



find more information by checking out the website listed below.

Contact  
T +44 (0)1454 620500  
sales@uk-spares.com  
www.uk-spares.com



## Genuine manufacturers' electrical spares from A to Z



## UK Spares: your one-stop-shop for domestic and commercial electrical spares

Call or email our friendly team TODAY...

www.uk-spares.com or email sales@uk-spares.com

Tel: 01454 620500 Twitter: @UKSpares

Unit 1155, Aztec West, Almondsbury, Bristol BS32 4TF





## ThinCats supports WRW Construction with multi-million pound funding solution

WRW is a family-owned, national construction company with offices in Llanelli, Cardiff and Bristol. The company has a track record of delivering award winning projects throughout Wales and the West of England, with over 700 projects completed in the last 33 years. The company delivers new build construction, restoration, renovation and refurbishment projects to clients across commercial, residential, leisure and education sectors.

Impressive growth has been achieved in recent years with the business delivering a turnover in excess of £60 million in 2018. Significant further growth is expected and underpinned by a strong secured pipeline of over £120 million.

The transaction provides WRW with a flexible, multi-million pound facility for working/growth capital purposes.

Jon Williams, Managing Director of WRW said, "We are on track to break revenues of £70 million this year with an enviable orderbook of over £120 million under contract. Despite the well documented challenges the industry and indeed the wider economy is facing, we were delighted to have been able to pick from a range of finance offers to take us forward.

"By choosing ThinCats as our long-term finance partner, it will further strengthen our position as one of the leading Main Contractors in Wales and the South West of England over the coming years."

Alison Whistance, Director Regional Business Development, ThinCats said, "ThinCats are very proud



to support WRW with its continued growth and this facility provides the funding required delivering their strong pipeline into 2020 and beyond. This is a great example of what ThinCats does best, we worked closely with Gambit and the management team to provide a flexible solution that was bespoke for the business. It was a pleasure to work with all parties involved and we wish WRW continued success for the future."

Alex Jenkins, Finance Director of WRW said, "The Gambit and ThinCats teams were excellent throughout in cutting through the noise of such a significant and often complex strategic decision to advise and develop the best finance proposition for WRW to meet its business plan. It's great to reach such a noteworthy milestone as we look to improve our offer to both our clients and supply chain."

T +44 (0)1530 444040  
www.thincats.com

## ThinCats provides new debt facilities to secure REAMS growth ambitions

ThinCats, the leading fintech lender to mid-sized SMEs, has provided new debt facilities to accelerate building engineering consultancy, REAMS, ambitious growth plans. Lexington Corporate Finance acted as the lead advisor to REAMS on the fundraise.

Based in South Wales, REAMS is a building engineering consultancy providing technical asset management solutions across the built environment to a number of blue-chip companies across the UK and Europe. The new funding will allow the company to accelerate its growth plans in its core business, whilst also assisting in the further development and commercial rollout of its own in-house asset lifecycle software, ELIAS.

Founded in 2007 by its CEO, Alistair Clements, REAMS is now the leading business operating in this sector in the UK. The company works with its customers to collate, process, interpret and aggregate building construction and performance data in order to provide cost-effective building management and maintenance strategies across estates.

The ThinCats team, led by Alison Whistance and David Jamieson, worked closely with senior management at REAMS, and senior advisors at Lexington, Gary Partridge and Thomas Edwards, to complete the transaction.

Kevin Dewhurst said, "The willingness of ThinCats to develop a flexible solution aligned to our strategy was evident from the first introduction meeting. This, along with ease of access to funds was differentiating factors in a competitive process. The funds will contribute to the development of our ELIAS software which will facilitate growth and expansion of our core services in a Facilities market that is increasingly using technology and data to drive Asset Management strategies."



THINCATS

Thomas Edwards, Lexington's Director, said, "We are delighted to have advised REAMS on this transaction. The Company has an excellent reputation in its sector and has seen significant growth during the past 12 months and is a great example of an innovative Welsh business looking to expand. The funding from ThinCats will allow the business to continue to grow and differentiate itself from its competitors."

Alison Whistance, Director of Business Development for South West and Wales, ThinCats, said, "I am delighted to support REAMS with their ambitious growth plans and the development of their market-leading ELIAS software which will further enhance the customer experience and service offering. REAMS are led by an experienced management team who are well-respected in the industry, we are proud to be their chosen funding partner and look forward to supporting their further growth."

T +44 (0)1530 444040  
www.thincats.com

## Specialist suppliers of Premium Oak Products

Founded by current Managing Director, Darren David Dack, 3D Oak supplies European oak framed buildings/cart lodges of the finest quality. Darren is of the firm belief that the key to producing great timber framed buildings is good design, and the team at 3D Oak is committed to offering superior products and services with good value for money.

3D Oak offers an array of standard or bespoke designs which are supplied to both the building trade and private individuals. As well as framed buildings/cart lodges, the company is also a specialist supplier of other oak products: garden rooms, log stores, porches, gazebos, pergolas,



workshops, offices, stables, beams, trusses, bollards, and many others. What's more, all of these

can be delivered directly to your door, and 3D Oak delivers manufactured oak frames in kit form within just six weeks of order confirmation.

Dedicated to providing friendly and professional advice about a project, 3D Oak strives to build strong relationships with their clients, with a passion for bringing a creative flair to everything they do.

Contact  
T +44 (0)1371 829224  
M +44 (0)7852 335999  
info@3doak.co.uk  
www.3doak.co.uk

## Stunning Timber Door Canopies by George Woods



With over 27 years of experience in designing and handcrafting timber door canopies, George Woods offers only the very best. Made in the heart of Devon, their traditional timber door canopies are made with the finest red cedar wood, ensuring durability, quality and beauty. Their materials are all sourced from sustainable forestry, and George Woods is committed to offering the very best in quality and customer care.

The company boasts a vast range of door canopies, offering numerous designs to suit the style of each home. George Woods can supply anything from flat roof canopies to 'A' frame door canopies and mono pitch, all of which are self-assembly. Indeed, George Woods ensures the canopies are quick and easy to fix, with full instructions supplied with every product.

Now supplying hardwood, glass and GRP canopies, customers can purchase these stunning door canopies online, where they can be delivered nationwide and beyond. Certainly, George Woods is committed to making sure the beauty of Devon cottages is spread throughout the country.

What's more, as well as their popular range of designs, George Woods can design and build a canopy unique to you and your home, as well as adjusting dimensions of existing canopies to suit your needs.

For more information, head to their website or use the contact details below.

T +44 (0)1363 884218  
sales@timberdoorcanopies.co.uk  
www.timberdoorcanopies.co.uk

### 3D OAK LIMITED, MANUFACTURED TRADITIONAL OAK FRAMES

We supply quality European oak framed buildings/cart lodges delivered direct to your door.

We provide a comprehensive range of standard or bespoke designs, to both the building trade and private individuals, and to suit all needs. We are also specialist suppliers of many other high quality oak products including garden rooms, log stores, porches, gazebos, pergolas, workshops, offices, stables, beams, trusses, bollards and much more. We offer excellent value for money enabling us to deliver many manufactured oak frames in kit form to you within six weeks of order confirmation.

CART LODGES • CONSERVATORIES • GARDEN ROOMS • ORANGERIES  
PORCHES • PERGOLAS • GAZEBOS • GARDEN FURNITURE  
MISCELLANEOUS

Please visit [www.3doak.co.uk](http://www.3doak.co.uk)  
01371 829224 | 07852 335999

## TIMBER DOOR CANOPIES

### DESIGNED BY GEORGE WOODS

Is it a door canopy? Or is it a porch? Well it's both! And if you want to make your house a little more interesting then you have come to the right place. We are the home of traditional handcrafted, beautiful, timber door canopies, made in the heart of Devon. We use the finest red cedar wood, for durability, quality and beauty, and all our wood comes from sustainable forestry. Let George Woods help you, give your home a new identity.

- UK Handmade
- Sustainable Timber
- Bespoke Orders taken
- Next Day Delivery
- Prices given on bulk orders
- Prices from **£235.00**

[www.timberdoorcanopies.co.uk](http://www.timberdoorcanopies.co.uk)  
Please contact 01363 884218  
sales@timberdoorcanopies.co.uk

George Woods (SW) Ltd



## Revealed: The hard task of countering a concreteberg

Wastewater engineers from Lanes Group plc are working with colleagues at Thames Water to keep water flowing around a giant 'concreteberg' blocking a sewer in North London.

The giant plug of concrete, thought to be up to 100 metres long and weighing up to 105 tonnes, the same as a blue whale or 20 elephants, was discovered by a Lanes CCTV survey team in Goswell Street, Islington.

It was christened a concreteberg after fatbergs – large blobs of fat, oil and grease (FOG) and wet wipes that also regularly block urban sewers – and is the largest mass of the building material ever found in a London sewer.

Lanes, the wastewater network services maintenance

partner for Thames Water, has put in place an emergency sewer monitoring and maintenance programme to protect local homes and businesses from sewer flooding.

The emergency concreteberg response team is made up of a seven-person confined space entry team, which includes two rescue personnel, all qualified to use breathing apparatus, a jet vac tanker team, a CCTV drainage survey team and two managers.

A parallel team of Thames Water sewer network engineers and specialists are also working on the project to support Lanes and identify the best way to clear the concrete which is stuck fast to the walls of the 1.2-metre-high brick-lined Victorian sewer.

In the days after the concreteberg was discovered, in the second week of April 2019, Lanes personnel used robotic cameras and sewer walks to survey 550 metres of sewer to assess its impact on the local drainage system.

They then cleaned 350 metres of main sewer. This included the 230-metres of the Moreland Street local sewer that connects the Goswell Road sewer with the London Bridge main line sewer, which runs parallel to it.

**Contact**  
T 0800 526488  
sales@lanesgroup.co.uk  
www.lanesfordrains.co.uk



## Leading Services in the Water Industry



H.D. Services Ltd was first established in 1984 by current company Director, Frank Harris. Based in Buckinghamshire, the company operate throughout the South East and specialise in the design, supply, installation and maintenance of sewage treatment systems, open-loop ground source heat pump systems, water supply boreholes, soakaways and drainage - all the utilities a self-builder may require.

Customer service is at the forefront of the company which is why they provide on-hand advice and support on dealing with the Environment

Agency, applying for the domestic Renewable Heat Incentive, and in regards to the several different services they provide. H.D Services have been recognised for their exceptional products and services,

receiving regional awards at the South East Green Deal and ECO Awards 2015, the Energy Efficiency and Retrofit Awards in 2016, the Energy Efficiency and Health Homes Awards 2017 and the Energy Efficiency Awards 2018.

Having won awards for their renewable heat installations, we asked Rebecca Taylor (Business Development Manager) what the benefits were. "We strongly believe that the open-loop ground source heat pump systems we design and install are not only the most efficient way to heat your home in our operational area, but also do less damage to the aquifers than drilling for closed-loop borehole systems, as predominantly these use the rotary drilling method. We aim to provide the highest quality open-loop ground source heat pump service available in South East England."

**Contact**  
T +44 (0)1494 792000  
enquiries@thehdgroup.co.uk  
www.hdservicesltd.co.uk





With over 30 years experience, we offer bespoke solutions for the domestic market throughout the South East. A free feasibility study can usually be determined upon receipt of a site postcode.

### Ground Source Heat Pumps



H.D. Services Ltd is an award winning fully MCS accredited company providing the highest quality Open-Loop Ground Source



Heat Pump installations in South East England. We design bespoke systems using MCS accredited British manufactured heat pumps.

Our installations can reduce energy bills by more than 50%. We provide a one-stop solution for the domestic market

throughout South East England which includes:

- FREE feasibility study
- Complete supply and installation
- Fully qualified and accredited staff
- Support in applying for the RHI
- Annual Maintenance Programme
- MCS accredited installers

[www.hdservicesltd.co.uk](http://www.hdservicesltd.co.uk)  
enquiries@thehdgroup.co.uk | 01494 792000







## WETROOMS ONLINE

THE UK'S WET ROOM EXPERTS

**When it comes to wet rooms WE are the EXPERTS!**

As the leading wet rooms retailer in the UK, Wetrooms Online are here to help.

Our range of wetroom kits makes installing a wet room quick and easy.

**FREE UK DELIVERY on all orders over £100**



WET ROOM KITS | SHOWER SCREENS | WALL PANELLING  
UNDER FLOOR HEATING | INSULATION BOARD | TANKING

[www.wetroomsonline.co.uk](http://www.wetroomsonline.co.uk)  
**Freephone: 0800 280 8008**



# QUAD-LOCK®

## Insulated Concrete Forms for Amazing Buildings

Quad-Lock Building Systems provide a fast-build and high performing building envelope to the UK construction industry. Quad-Lock Insulating Concrete Forms serve to provide robust concrete buildings and stay in place insulation resulting in safer, more comfortable and ecologically sound homes and commercial buildings.

We provide the most cost-effective method to reach Code for Sustainable Homes Levels 3 to 6, PassivHaus, BREEAM and Building Regulation requirements.

For more information, please contact Stephen Campbell on: **+44 (0)7771 311311** or visit [www.quadlock.co.uk](http://www.quadlock.co.uk)



## Retrofitting roofs with Solar PV



When maintaining or upgrading buildings, clients are constantly looking to make the smartest investment and improve energy efficiency. By retrofitting photovoltaic (PV) panels onto a roof it can not only produce cheap, clean electricity for the building's use, but also help landlords and building owners reduce their carbon emissions and hit the standards and

regulations for energy efficiency in buildings such as MEES (minimum energy efficiency standards) that came in to play for landlords this April.

The roof survey stage of a refurbishment project is the ideal occasion for surveyors to propose an on-site rooftop solar PV solution to a client as it creates a great opportunity to review and discuss the suitability of a solar PV installation.

Arguably the most fundamental considerations when contemplating a PV retrofit to a flat roof are weight loadings and design calculations; however, another significant factor is ensuring that waterproofing

membranes are in a suitable condition, that waterproofing warranties will not be impacted, and the life expectancy of the waterproofing system matches that of the new technology.

Discounting this consideration could potentially result in the array needing to be removed early in order to reinstate the integrity of the roof. Thus, the ideal time to add photovoltaics is to do it simultaneously when refurbishing the waterproofing system.

For more information on how Bauder can support your rooftop renewable energy proposal to a client, call +44 (0)845 271 8800.



**GLOBAL SURVEY EQUIPMENT**

Fully Authorised Distributor & Service Partner Of

**GE MAX**



Based in the heart of the North West of England, means we are able to easily access the extensive motorway network, making it possible for us to offer an outstanding delivery service to all our customers. As a company we don't focus on just one area, we have four main areas of expertise within the survey equipment industry.

**OUR FOUR MAIN AREAS OF EXPERTISE:**

- Sales
- Repair & calibrations
- Training
- Hires

**Global Survey Equipment Ltd**  
The Sawmills, 52 Rosedale Avenue,  
Atherton, Manchester, M46 0DZ

T: 01942 896 244  
E: sales@globalsurveyequipment.com  
[WWW.GLOBALSURVEYEQUIPMENT.COM](http://WWW.GLOBALSURVEYEQUIPMENT.COM)

**OUR SUPPLIERS**

## Innovation from the ground up



If you are specifying a stormwater system, it pays to consult Tubosider. We are the leading UK manufacturer of corrugated steel pipe for WRc approved stormwater management and attenuation tank systems, culverts and tunnels.

Our products provide an infinite variety of layouts. That means you get a simpler, more flexible, storm water solution with less waste, less cost to you and an installation that's often just a simple pipe-laying exercise.

### Why choose a steel system?

The versatility and strength of steel makes it an obvious choice when compared to concrete or plastic systems. Our steel systems can be precisely engineered and the finished product fabricated to exact specifications.

The loadbearing capabilities of our products mean they are compliant to Highways Agency Standard BD12, with a minimum design life of 60 years. We can design in a greater steel thickness or with Trenchcoat Polymer Secondary Coating to give you a system with up to 120 years' design life or for an aggressive environment.

We recognise that our customers are required to provide increasingly more sustainable and ecologically sound solutions on site. Our pipes are made from 25% recycled steel, and our attenuation tanks are 100% recyclable. You won't find that level of sustainability with a plastic or concrete system.

### Value engineered

Our WRc certified Singlestore and patented Twinstore attenuation systems are used in construction projects across the UK. You can rely on our tanks to provide better value than a cellular crate system. Time and again our systems require fewer manholes and less underground pipework saving time and money.

As a minimum, we can reduce the number of manholes required for a crate system by two, and normally many more. Plus, installing one of our conventional tanks often means that you can use a full retention separator, providing a further cost saving.

T +44 (0)1744 452900  
[info@tubosider.co.uk](mailto:info@tubosider.co.uk)  
[www.tubosider.co.uk](http://www.tubosider.co.uk)



# H Bells banks on Polyflor for indoor market transformation

A selection of Polysafe and Expona products were the floor of choice for H Bell and Sons as they undertook the transformation of a former bank building into a stylish new indoor market, complete with café and fresh food stalls.

Set in Rochdale Town Centre, the three storey, 1920s property has been turned into a brand new shopping and eating hub alongside the River Roch. Extensive work has been undertaken with the creation of a new atrium, a new roof and installation of lifts before reinforcing the floors ready for a selection of new Polyflor floor coverings including Expona Commercial Aged Elm, Polysafe Apex Chromite, and Expona Flow Smoked Oak.



Expona Flow was fitted for the walkways and the restaurant. Specifically created for very heavy commercial environments, the collection was the perfect choice as it encompasses beautifully replicated wood planks in a practical and durable vinyl sheet format whilst leaving a stylish, high-end finish. All Expona products are enhanced with Polyflor PUR, Polyflor's exclusive and robust polyurethane reinforcement which is cross linked and UV cured to provide superior cleaning benefits and a cost-effective maintenance regime.

Expona Commercial, fitted on the top floor, made the ideal choice as it is suitable for high traffic areas such as a restaurant or commercial shopping

area. Created to bring flooring solutions that are tailor made to suit the customers vision with reproductions of the widest range of natural and man-made materials combined with innovative modern finishes.

Sampling from all ranges can be ordered free of charge on the Polyflor website or by calling the Polyflor Samples Direct Hotline on: +44 (0)161 767 2551. All contain recycled material and are 100% recyclable via the Recofloor vinyl take back scheme.

T +44 (0)161 767 1111  
info@polyflor.com  
www.polyflor.com

## Polyflor adds EnCore Rigid Loc to the Expona family of premium vinyl floorcovering



Polyflor, the UK's commercial and residential vinyl flooring specialist is pleased to announce the launch of a brand new product format, the Expona EnCore Rigid Loc collection. This exciting new hybrid product has an expertly engineered premium rigid SPC (Stone Polymer Composite) construction with exceptional stability making it ideal for installation over existing subfloors. Expona EnCore's technically sophisticated specification combines:

- 1) A premium rigid SPC core
- 2) 0.55mm heavy commercial wear layer
- 3) High clarity decoration layer
- 4) 1mm IXPE acoustic backing layer
- 5) 5G-i locking technology

Whether designing a large scale commercial installation or a warm and inviting home interior scheme, aesthetics are just as important as practicality, especially when considering a floor covering. Expona EnCore Rigid Loc offers a flooring solution that caters for both commercial and residential interiors. The rigid construction gives the floor exceptional stability and its acoustic foam layer reduces impact sound by 19dB, exceeding UK building regulations whilst also providing comfort and warmth underfoot. The use of 5Gi click-locking technology provides superior performance in a quick to install floor covering and the loose lay format means no adhesive is required, reducing installation time and cost.

The collection features 12 faithfully replicated wood designs that have been expertly selected bringing together the natural beauty of timber and its authentic surface textures. The Expona EnCore Rigid Loc collection encompasses a wide spectrum of wood species to suit any commercial or residential interior with each design featuring fine grain and knot detailing and micro bevelled edges for a timeless appearance typical of real wooden floorcoverings.

Polyflor's unique polyurethane reinforcement creates a scratch and stain resistant finish that makes it ideal for modern households with families and pets, as well as heavy commercial interiors with high foot traffic. Expona EnCore Rigid Loc is also 100% waterproof and an ideal alternative to hardwood flooring, offering all the beauty of real wood with the resilience of vinyl.

Expona EnCore is beautifully presented within a sampling package which includes a brochure and a comprehensive presenter. Sampling can be ordered free of charge on the Polyflor website or by calling the Polyflor Samples Direct Hotline on +44 (0)161 767 2551. Expona EnCore's environmental credentials are impressive, achieving a generic BRE A+ rating in major use areas and Indoor Air Comfort Gold, assuring that VOC emissions are below any globally determined levels. It is also 100% recyclable via the Recofloor recycling scheme and contains an average of 15% recycled content.

T +44 (0)161 767 1111  
info@polyflor.com  
www.polyflor.com

## THE SELF BUILD LOAN FUND

HERE TO HELP THOSE STRUGGLING TO SECURE SELF BUILD FINANCE

Scottish Government  
Riaghaidhs na h-Alba  
gov.scot

THE HIGHLANDS SMALL COMMUNITIES HOUSING TRUST

**The Self Build Loan Fund is a Scottish Government fund set up to financially support self builders during their construction process. Applicants can borrow up to £175,000 and repay their loan on completion with a traditional mortgage. Applicants must own a plot with planning consent in place. Fees and interest apply.**

**For more information please visit our website:  
www.hscht.co.uk/scotland-self-build-loan-fund**

GET IN TOUCH

01463 572 030
selfbuild@hscht.co.uk
www.hscht.co.uk

The Highlands Small Communities Housing Trust is a Company Limited by Guarantee(SC182662) and a Scottish Charity (SC027544).

## The Sign Maker

www.sign-maker.net

01769 561355

## Drive to Success with Resin Drives

Choose a resin bound installation team with BBA certification and over 10 years experience:

- ✓ Ideal for public pathways, hotels, car parks and leisure facilities
- ✓ Quick drying time to allow access as soon as possible
- ✓ 10 times more environmentally friendly than concrete
- ✓ Wheelchair friendly with anti-slip surface and great tyre traction for public safety

**Alternatively, order resin supplies online for your landscaping business**

- ✓ Guaranteed next day delivery
- ✓ Two optional pick-up points
- ✓ Expert advice and hands-on training
- ✓ Huge range of dried aggregates, rubber mulch and resin grid systems

Call 01274 699233 for commercial installation  
or visit [www.resindrivetrade.co.uk](http://www.resindrivetrade.co.uk) to order online

**Collection Points**

West Yorkshire

01274 699233

Unit 4D Armytage Road  
Brighouse HD6 1QF

South Wales

01656 667866

Unit 17A Kingsway Buildings  
Bridgend Ind Est, Bridgend CF31 3RY

Approved Materials & Systems  
Cert No: 185476

RESIN TRADE SUPPLIES

Resindrives.co.uk is a trading name of resindrives.co.uk Ltd.



## The Winn Building opens at Eastbourne College

Mr David Winn OBE, chairman of leading corrosion prevention and sealing specialists, Winn & Coales (Denso) Ltd, has been recognised for his ongoing support of Eastbourne College with a building on campus named in his honour.

The Winn Building is a new, purpose built facility featuring an array of state of the art amenities, including multiple sport and fitness suites, function rooms, dining facilities and classrooms. The opening of the Winn Building, named in recognition of the College's greatest living benefactor, signals the completion of Project 150 at the site in East Sussex, which saw a £33 million investment in the College campus to celebrate the school's 150th anniversary.

Winn & Coales (Denso) Ltd are a leading manufacturer of corrosion prevention systems for the long term protection

of above and below ground pipelines and steel structures. Their company chairman, Mr David Winn OBE, is only the third chairman in the company's 136-year history and has been with the company for over 53 years.

Mr Winn attended Eastbourne College from 1954-59, and today the school is one of the UK's leading independent co-educational day and boarding schools. Also a registered charity (No. 307071), Eastbourne College helps support a great number of its students with bursaries and educational scholarships, whilst also providing access to its many state-of-the-art facilities to the benefit of neighbouring schools and the wider community.

T + 44 (0)20 8670 7511  
www.denso.net



## TCFM contract at Eden Walk, Kingston



TC Facilities Management (TCFM) is now delivering Cleaning and Security Services at Eden Walk in Kingston, part of the Regional multi-let retail portfolio managed by Broadgate Estates and owned by British Land and USS. This new contract commenced on April 1st and will help enable the 10 million visitors that go to Eden Walk each year to have a safe and enjoyable shopping experience.

The team from TCFM, led by Andy Farley, TCFM Contract Manager, will ensure that the extensive cleaning & security expertise along with the standards that TCFM are renowned for in other Retail and Office sites are replicated, and with it will enable Eden Walk to provide visitors with an outstanding place to visit.

The contract will utilise smart management systems and state-of-the-art technology to help maintain and improve standards along with delivering robust monitoring and management reporting to Broadgate Estates, all with the aim of delivering unrivalled customer service and value.

Having been able to demonstrate added value within other cleaning & security contracts, the contract was awarded based on TCFM's proven track record spanning almost 55 years, along with their design of a bespoke solution, built on Broadgate Estates' individual needs.

T +44 (0)1737 814016  
info@tcfm.co.uk  
www.tcfm.co.uk

## TC Specialist Services bringing an extra sparkle to Poundland



TC Facilities Management (TCFM) have secured the contract to deliver window and external signage cleaning across the country.

The contract being delivered by a team from TC Specialist Services, part of TC Facilities Management (TCFM), started last month. It provides window cleaning services to every Poundland store, 4 DCs and their admin offices in the UK along with each Dealz store in the Republic of Ireland.

The team from TC Specialist Services are ensuring that the standards of appearance to the windows and external signage of each site will help to create a welcoming, fresh and engaging environment for Poundland's customers and suppliers.

The contract utilises innovative software which will help to deliver robust scheduling, monitoring and management reporting to Poundland.

Eric Dawson, Business Manager, TC Specialist Services said, "Having previously provided services to about half of Poundland sites, we are delighted to now be providing our services to their complete portfolio. This award of contract has been as a result of us building relationships over a 5-year period that demonstrate our efficient and proactive response to Poundland's needs, particularly by our helpdesk, led by Abby Tordoff."

T +44 (0)1737 814016  
info@tcfm.co.uk  
www.tcfm.co.uk

premier guarantee®

# KNOCK KNOCK

We're not joking around...

WE JUST WANTED TO LET YOU KNOW WE HAVE COVERED OVER £57BN WORTH OF PROPERTY ACROSS THE UK AND EUROPE

Find your Structural Warranty Solution  
PREMIERGUARANTEE.COM | 0800 107 8446

MD Insurance Services Ltd is the Scheme Administrator for the Premier Guarantee range of structural warranties.  
MD Insurance Services Ltd is authorised and regulated by the Financial Conduct Authority.



# Hauraton Service Channels keep cables safe but accessible

Hauraton Limited, well known for their surface water drainage products, also offer three ranges of Service Channel suitable for use as sub-surface cable ducting for both indoor or outdoor locations including; sports venues, major stadiums, exhibition halls, factories, warehousing and container depots. The channels provide safe yet accessible installation of electrical and data cables.

Two ranges are based on the company's one metre long fibre reinforced concrete channels, FASERFIX® SUPER and KS. The SUPER models incorporate a 40mm deep galvanised angled housings on their top edges allowing Class E600 ductile iron covers to be fitted. The KS models have a 20mm deep galvanised angled housing and are available for Class C250 or where necessary E600. The third range is based on Hauraton's RECYFIX® PRO channel made from 100% recycled polypropylene. These have a 20mm galvanised housing allowing Class C250 covers to be fitted. Weighing less than 25kg the PRO channels are suitable where easy handling is desirable.

With SUPER and KS models, the ductile iron covers are securely located into the housings by the company's SIDELOCK fixing system. To access the cables, covers are easily removed using a large screwdriver at the appropriate leverage points. In practice, the SIDELOCK system has proved to be 90% quicker than any other fixing method available. Where necessary, covers can be bolted down. PRO models have bolt down covers as standard.

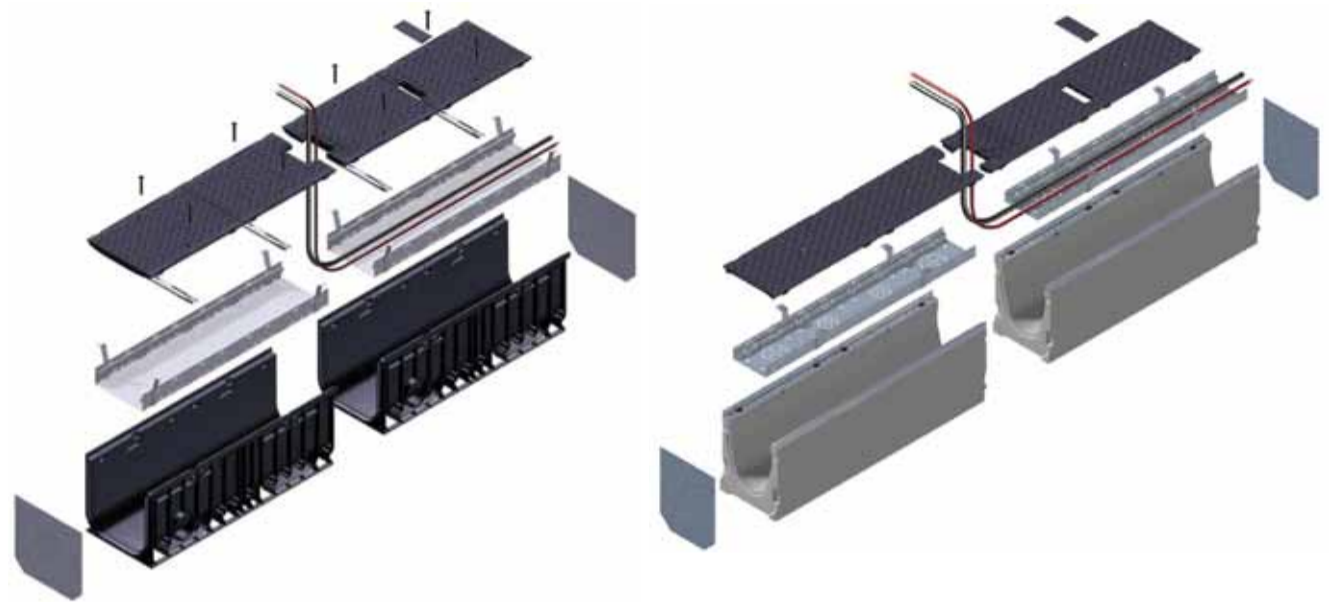

The popular nominal widths offered with Hauraton Service Channels are 200mm and 300mm. These models incorporate a perforated steel galvanised cable tray that is suspended within the channel keeping the cables clear of any water that may access the channel. The water can then be safely drained away.

Tim Connolly Managing Director at Hauraton explains, "Our Company have gained invaluable expertise

supplying Service Channels in to numerous buildings and venues including prestigious stadiums in many parts of the world. Architects, main contractors and ground-workers can request a hardcopy of our new brochure illustrating the full range of channels by telephoning: **+44 (0)1582 501380**. A PDF version is also available via: [www.hauraton.co.uk](http://www.hauraton.co.uk)."

For case studies featuring many Hauraton drainage products, go to: [www.drainage-projects.co.uk](http://www.drainage-projects.co.uk)

## Hauraton Channels installed at Oldham Academy North

The new Oldham Academy North, designed by architectural practice Aedas Architects, is a spacious and colourful three storey building set in sensitively landscaped grounds. With the site being quite flat, and the building surrounded by paved and asphalted surfaces, it was essential rainwater is drained effectively.

A Hauraton RECYFIX® PRO 100 channel system, fitted with FIBRETEC® C250, 9mm slot gratings, was used by groundwork sub-contractor Westoak Construction to drain the paved playgrounds and asphalted car parks. The channels were also installed along parts the building's façade and across entrance doors to facilitate drainage.

The FIBRETEC® C250 HEELSAFE slot grating was specifically designed by Hauraton R&D engineers to enhance the flow of water into the channel. The slots are super smooth, elliptical openings with the moulded bars having slightly raised triangular bosses along their outside edges. As well as providing an elegant appearance, the feature ensures surface water is directed into the slots. This configuration also helps eliminate any cross-flow over the grating.



The RECYFIX® channel component is made from 100% recycled PE-PP. The six sizes offered are 160mm wide and range in height from 75mm to 201mm with the FIBRETEC® grating factory fitted on all models. As the largest unit is only 4.6kg, RECYFIX PRO channelling is easily handle and quickly installed on-site.

Ian Burton, Hauraton's Project Engineer comments, "Light and dark grey granite paving blocks were used extensively to achieve a pleasing aesthetic appearance to the hard landscaping immediately surrounding the Academy buildings. Being particularly suitable for school yards and playgrounds, our RECYFIX® PRO channels' with their black FIBRETEC® gratings' were chosen for this project as the grating's smooth appearance blended in well with the desired design effect."

Contact  
T +44 (0)1582 501380  
[www.hauraton.co.uk](http://www.hauraton.co.uk)  
[www.drainage-projects.co.uk](http://www.drainage-projects.co.uk)